

S-104

Water Level Information for Surface Navigation Product Specification

Edition 2.0.0-2024-02-08

IHO



International
Hydrographic
Organization

Published by the
International Hydrographic Organization
4b quai Antoine 1^{er}
Principauté de Monaco
Tel: (377) 93.10.81.00
Fax: (377) 93.10.81.40
info@iho.int
www.iho.int

© Copyright International Hydrographic Organization 2024

This work is copyright. Apart from any use permitted in accordance with the Berne Convention for the Protection of Literary and Artistic Works (1886), and except in the circumstances described below, no part may be translated, reproduced by any process, adapted, communicated or commercially exploited without prior written permission from the International Hydrographic Organization (IHO). Copyright in some of the material in this publication may be owned by another party and permission for the translation and/or reproduction of that material must be obtained from the owner.

This document or partial material from this document may be translated, reproduced or distributed for general information, on no more than a cost recovery basis. Copies may not be sold or distributed for profit or gain without prior written agreement of the IHO Secretariat and any other copyright holders.

In the event that this document or partial material from this document is reproduced, translated or distributed under the terms described above, the following statements are to be included:

“Material from IHO publication [reference to extract: Title, Edition] is reproduced with the permission of the IHO Secretariat (Permission No/...) acting for the International Hydrographic Organization (IHO), which does not accept responsibility for the correctness of the material as reproduced: in case of doubt, the IHO’s authentic text shall prevail. The incorporation of material sourced from IHO shall not be construed as constituting an endorsement by IHO of this product.”

“This [document/publication] is a translation of IHO [document/publication] [name]. The IHO has not checked this translation and therefore takes no responsibility for its accuracy. In case of doubt the source version of [name] in [language] should be consulted.”

The IHO Logo or other identifiers shall not be used in any derived product without prior written permission from the IHO Secretariat.

Document History

Changes to this Specification are coordinated by the Tides, Water Levels and Currents Working Group (TWCWG). New editions will be made available via the IHO web site. Maintenance of the Specification shall conform to IHO Resolution 2/2007 (as amended).

Version Number	Date	Editor	Purpose
0.0.0	February 2015	Z Jayaswal	Initial Draft
0.0.1	May 2016	Z Jayaswal	TWCWG1 – Working group input incorporated from Brazil meeting.
0.0.2	August 2016	Z Jayaswal	TWCWG – incorporate feedback on Portrayal and Attributes.
0.0.3	March 2017	Z Jayaswal	Extract commonality from S-111 Ver. 0.1.10 to ensure consistency between standards.
0.0.4	May 2017	Z Jayaswal	As edited during TWCWG2.
0.0.5	November 2017	Z Jayaswal	Feedback from TWCWG and S-100WG.
0.0.6	September 2018	Z Jayaswal	Feedback from TWCWG3 and S-129WG.
0.0.7	March 2019	Z Jayaswal	Feedback from S100 Test Strategy Meeting Sep 2018.
0.0.8	April 2019	Z Jayaswal, K Hess & G. Seroka	Feedback from NOAA and TWCWG4.
0.0.9	April 2021	Z Jayaswal, G. Seroka, R. Malyankar Review by TWCWG and S-104 project team	Feedback from TWCWG5.
1.0.0 Draft 1	June 2021	R. Malyankar	Applied review comments on Ver. 0.0.9. Added carrier metadata attributes for coordinate systems approved by S-100WG. Added exchange set structure and use cases.
1.0.0 Draft 2	August 2021	R. Malyankar. Review by ZJ, GS.	Applied comments on Draft 1.
1.1.0-20220831	August 2022	R. Malyankar	Aligned with S-100 5.0.0; applied some of the held-over comments from Edition 1.0.0; new enumeration dictionary material
1.1.0-20230131	February 2023	R. Malyankar, G. Seroka	Fill value for waterLevelHeight now has 2 zeroes after decimal point; specified datatype size for HDF5 attributes; clarification of attribute dimension in feature type metadata; updated references; updated rules for dataset and support file names; guidance on (optional) ISO metadata; adjusted language on use of Schematron and digital signatures; added emphasis for differences between S-100 and S-104 exchange catalogues; added productIdentifier metadata attribute; added Res. 3/1919 as a separate reference. Figures in Annex E removed.

1.1.0	April 2023	R. Malyankar	Applied TWCWG review feedback; corrected S-100 error in digital signature types in metadata.
2.0.0-20240131	January 2024	R. Malyankar	References updated; registry producer code URL replaced with main page URL; citation of S-100 WG7 paper removed and usage sentences updated (register is now active in the GI registry); multiple changes to reduce scope of S-104 reduced to regular grids per S-100 WG8; alignment with S-100 Edition 5.2; additional EPSG codes for horizontal reference systems; removed Annex B (Additional terms...); uncertainty attribute added (TBD); restricted maximum length of HDF5 string attributes (clause 12.3)
2.0.0-20240208	February 2024	R. Malyankar	Added attribute <i>verticalCoordinateBase</i> (Table 12-1); sequencing rule must be linear (implicit in regular grid format); instance metadata constraints (Table 12-3) adjusted for WLA compatibility

Contents	Page
1 Overview	1
1.1 Introduction.....	1
1.1.1 Data types	1
1.1.2 Display.....	1
1.1.3 Encoding.....	1
1.2 Scope	2
1.3 References	2
1.3.1 Normative	2
1.3.2 Informative.....	2
1.4 Terms, definitions and abbreviations	3
1.4.1 Terms and definitions	3
1.4.2 Abbreviations.....	6
1.4.3 Notation	7
1.5 Use of language	8
1.6 General data product description	8
1.7 Data Product Specification metadata.....	8
1.7.1 IHO Product Specification maintenance.....	9
2 Specification Scopes	9
3 Dataset Identification	10
4 Data Content and Structure	11
4.1 Introduction.....	11
4.2 Application Schema	11
4.3 Feature Catalogue.....	11
4.3.1 Introduction.....	11
4.3.2 Feature types.....	12
4.3.3 Feature relationship.....	12
4.3.4 Attributes	12
4.3.5 Spatial quality	12
4.4 Dataset types	13
4.5 Spatial Schema	13
4.5.1 Coverages	13
5 Coordinate Reference Systems (CRS)	14
5.1 Horizontal reference system	14
5.2 Vertical reference system.....	15
5.3 Temporal reference system	16
6 Data Quality	16
6.1 Introduction.....	16
6.1.1 Data quality metadata (informative)	16
6.1.2 Data quality elements and data quality measures	16
6.2 Additional components of data quality	19
6.3 Assessment of data quality	20
6.4 Validation checks	20
7 Data Capture and Classification	21
7.1 Data sources for water levels.....	21
7.1.1 Determination of trend.....	22
7.2 The production process.....	22
7.2.1 Metadata.....	22
7.2.2 Water Level Data.....	23
7.2.3 Validation.....	23
7.2.4 Digital Signatures	23

7.3	Guidance for chunking and compression (informative)	24
7.4	Datasets in a series	24
7.5	Data use purpose	25
7.5.1	Datum requirements	25
7.5.2	Spatial type	25
7.5.3	Suitability for navigation	25
7.5.4	Use purpose metadata	25
7.6	Compliance categories	25
7.7	Compliance with S-98	25
7.7.1	Requirements for visual interoperability	25
7.7.2	Requirements for harmonised user experience	26
7.7.3	Requirements for water level adjustment	26
8	Maintenance	26
8.1	Overview of dataset maintenance	26
8.1.1	Update of harmonic constants (informative)	26
8.2	Metadata related to dataset maintenance	27
8.2.1	Elements used in S-104	27
8.2.2	New datasets	27
8.2.3	New Editions	28
8.2.4	Cancellations	28
8.2.5	Other <i>S100_Purpose</i> values (informative)	29
8.2.6	Maintenance of support files	29
8.2.7	Encoding update frequency	29
9	Portrayal	29
10	Data Product Format (Encoding)	30
10.1	Introduction	30
10.2	HDF5 product structure for time series and gridded data	30
10.2.1	Data type definition	30
10.2.2	Product structure	31
10.3	Sample HDF5 encoding	35
11	Data Product Delivery	36
11.1	Introduction	36
11.2	HDF5 dataset packaging	36
11.2.1	Exchange Sets	36
11.2.2	Exchange Catalogue	39
11.2.3	Dataset file naming	39
11.2.4	Support files	40
11.2.5	Support file naming	40
12	Metadata	40
12.1	Introduction	40
12.1.1	Realisation of Exchange Set components and metadata classes (informative)	41
12.1.2	Exchange Set components and related metadata	42
12.2	Discovery metadata	44
12.2.1	S100_ExchangeCatalogue	47
12.2.2	S100_ExchangeCatalogueIdentifier	48
12.2.3	S100_CataloguePointofContact	48
12.2.4	S100_DatasetDiscoveryMetadata	49
12.2.5	S100_NavigationPurpose	52
12.2.6	S100_DataCoverage	52
12.2.7	S100_Purpose	53
12.2.8	S100_TemporalExtent	54
12.2.9	S100_EncodingFormat	54
12.2.10	S100_ProductSpecification	54

12.2.11	S100_ComplianceCategory.....	55
12.2.12	S100_ProtectionScheme.....	55
12.2.13	S100_SupportFileDiscoveryMetadata.....	56
12.2.14	S100_SupportFileFormat.....	57
12.2.15	S100_SupportFileRevisionStatus.....	57
12.2.16	S100_SupportFileSpecification.....	57
12.2.17	S100_ResourcePurpose.....	58
12.2.18	S100_CatalogueDiscoveryMetadata.....	58
12.2.19	S100_CatalogueScope.....	59
12.2.20	MD_MaintenanceInformation.....	59
12.2.21	MD_MaintenanceFrequencyCode.....	60
12.2.22	PT_Locale.....	60
12.2.23	S100_SE_CertificateContainer.....	61
12.2.24	S100_SE_DigitalSignatureReference.....	61
12.2.25	S100_SE_DigitalSignature.....	61
12.2.26	S100_SE_SignatureOnData.....	62
12.2.27	S100_SE_SignatureOnSignature.....	62
12.2.28	DataStatus.....	63
12.2.29	EX_GeographicBoundingBox.....	63
12.2.30	EX_BoundingPolygon.....	64
12.3	Carrier Metadata.....	66
12.3.1	General metadata - details.....	72
12.3.2	Feature Type metadata - details.....	75
12.3.3	Feature Instance metadata - details.....	76
12.3.4	Values Group attributes - details.....	77
12.3.5	Additional enumerations used in carrier metadata.....	78
12.4	Language.....	81
ANNEX A – Data Classification and Encoding Guide.....		82
A-1	Features.....	82
A-2	Feature Attributes.....	82
ANNEX B – S-104 Comprehensive Model Including Application Schema and Carrier Metadata (UML Diagrams).....		84
ANNEX C – Feature Catalogue.....		91
ANNEX D – Sample HDF5 Encoding.....		96
ANNEX E – Validation (Informative).....		99
E-1	Introduction.....	99
E-2	Check Classification.....	99
E-3	Check Application.....	99
E-4	Validation Steps.....	99
E-4.1	Dataset validation.....	99
E-4.2	Exchange Set validation (informative).....	101
E-4.3	System validation (informative).....	102
E-5	Check Description Format.....	102
E-5.1	Specification of validation checks.....	102
E-5.2	Phase initialization.....	103
E-5.3	List of checks.....	103
E-6	Test Cases and Methods.....	103
E-6.1	Coverage consistency.....	103
E-6.2	Logical consistency.....	104
ANNEX F – Use Cases.....		105
F-1	German Water Level Data and Forecast.....	105
F-1.1	Summary.....	105

- F-1.2 Additional details 105
 - F-1.2.1 Types of data used to create S-104 test datasets..... 105
 - F-1.2.2 Data processing..... 106
 - F-1.2.3 S-104 data transformation 106
 - F-1.2.4 Results..... 106
- F-2 Depth Adjustment in ECDIS..... 107
 - F-2.1 Summary 107
 - F-2.2 Additional details 108
 - F-2.2.1 Types of data 108
 - F-2.2.2 Processing..... 108

FOREWORD

The International Hydrographic Organization Tides, Water Level and Currents Working Group (TWCWG) remembers Kurt Hess, and acknowledges his invaluable and significant contributions in developing this Product Specification within the TWCWG.

Page intentionally left blank

1 Overview

S-104 is the Water Level Information for Surface Navigation Product Specification, produced by the IHO. This edition of S-104 is intended for use with the “water level adjustment” functionality described in IHO Publication S-98.

The development of electronic navigation with high resolution bathymetric data, and the drive to increase safety of navigation are now demanding time-sensitive data. IHO has identified the requirement for a Product Specification for dynamic tidal and water level data.

Tidal height information has traditionally been provided as high/low predictions; however, with increasing drafts and technology, there has been a move to hourly or more frequent predictions with major ports providing real-time water level information to their pilots and web-sites.

In order to allow applications to dynamically adjust depths, there is a requirement for S-104 Edition 2.0.0 to supply water level data as gridded surface time-series data compatible with the IHO S-102 (Bathymetric Surface) and S-101 (Electronic Navigation Chart) data products.

1.1 Introduction

Kommenterad [rmm1]: Revise to allow only gridded types

Tidal and water level predictions have been fundamental in route planning and entry to ports (SOLAS Chapter V). These have traditionally been supplied as a physical hard copy publication and recently as a separate software installation that may not be integrated with the ECDIS. New functionality is now being defined to integrate dynamic water level information into ECDIS. To improve safety of navigation, this product specification will ensure that tidal and water level data supplied for dynamic capability is consistent by all approved authorities.

Annex C of IHO Publication S-98 describes ECDIS functionality for combining dynamic water level information with bathymetric data to present ship’s officers with a more accurate picture of water depth over an interval. Given the technological ability to generate short-term dynamic forecasts of water level information and communicate them to vessels more frequently, this allows provision of more timely and accurate look-ahead depth information which can be used for more accurate estimation of navigability and hazard assessment by ship’s officers and watchstanders.

1.1.1 Data types

This edition of S-104 describes one data type that can be delivered to recipients such as ECDIS or other applications, either on board a vessel or in a shore installation:

1. A time series of water level height relative to a vertical datum and water level trend. The data represent an array of points contained in a grid. Time and datum information are contained in the metadata. The primary purpose of this data type is to enable displays of dynamic depth information on ECDIS in combination with bathymetric data; another purpose is to update water depths for under-keel clearance management.

1.1.2 Display

This edition of S-104 is designed for a single means of displaying water level data to support navigation, route planning, and route monitoring:

- Adjusted display of depths from datasets containing bathymetric data or electronic nautical chart information. This will be described in S-98 Annex C.

1.1.3 Encoding

There is one encoding of water level data:

1. HDF5 (Hierarchical Data Format version 5) is used for encoding time series of water level heights and trends (and optionally, uncertainty) at an array of points in a grid. HDF5 promotes compatible data exchange due to its common neutral encoding format. HDF5 is object oriented and suitable for many types of data.

Table 1-1 summarises Clauses 1.1.1 through 1.1.3.

Table 1-1 – S-104 data variables, formats, encoding and display.

NOTE: O = Overlay: a layer superimposed on and georeferenced to a nautical chart. I = Inset: a graphic that can be placed anywhere on the screen.

Data Variable	Data Format	Encoding	Display
Water level height	Multiple Locations, Time Series (i.e., Gridded Forecast), as values records combining all attributes.	HDF5	According to data product with which S-104 data is combined, with depth values and uncertainties adjusted. For example, bathymetry coverage or ENC feature display with shade according to adjusted depth.
Water level trend			Not included in S-98 Ed. 1.0/1.1 Annex C water level adjustment. Should be included in pick report if pick reports are implemented.
Uncertainty			Combined with uncertainty in data product with which S-104 data is combined.

1.2 Scope

This document describes an S-100 compliant Product Specification for the encapsulation and data transfer of tidal and water level data for use in an Electronic Chart Display and Information System (ECDIS) or any proposed dynamic tide application. This Product Specification includes the content model, the encoding, the feature catalogue and metadata. The water level product may be used either alone or combined with other S-100 compatible data.

1.3 References

1.3.1 Normative

HDF5	<i>Hierarchical Data Format version 5</i> – www.hdfgroup.org
M-3	<i>Resolutions of the International Hydrographic Organization, IHO Publication M-3, 2nd Edition, 2010 (updated July 2023)</i>
Res. 3/1919	IHO Resolution 3/1919 (as amended), IHO Publication M-3
S-44	<i>IHO Standards for Hydrographic Surveys, 6th Edition, September 2020</i>
S-62	List of Data Producer Codes (online), IHO GI registry, URL: https://registry.iho.int
S-97	<i>IHO Guidelines for Creating S-100 Product Specifications, Edition 1.1.0, June 2020</i>
S-98	<i>Data Product Interoperability in S-100 Navigation Systems, Edition 1.1.0, September 2024 (in preparation)</i>
S-100	<i>IHO Universal Hydrographic Data Model, Edition 5.2.0, June 2024</i>
S-158	S-100 Validation Checks (in preparation)

1.3.2 Informative

IALA G1143	<i>Unique Identifiers for Maritime Resources, Edition 3.0. International Association of Marine Aids to Navigation and Lighthouse Authorities, June 2021</i>
IOC 14-4	<i>Manual on Sea-level Measurements and Interpretation, Volume IV : An update to 2006. Paris, Intergovernmental Oceanographic Commission of UNESCO. (IOC</i>

Kommenterad [rmm2]: Add year of publication for ISO standards – compare to S-111 1.2.0 final

Manuals and Guides No.14, vol. IV; JCOMM Technical Report No.31; WMO/TD. No. 1339)

- ISO 3166-1:1997 *Country Codes*
- ISO 8601:2004 *Data elements and interchange formats - Information interchange - Representation of dates and times*
- ISO/TS 19103:2005 *Geographic information – Conceptual schema language*
- ISO 19111:2003 *Geographic information – Spatial referencing by coordinates*
- ISO 19115-1 *Geographic information – Metadata – Part 1 – Fundamentals*. As amended by Amendment 1, 2018
- ISO 19115-2:2009 *Geographic information – Metadata: Extensions for imagery and gridded data*
- ISO 19115-3 *Geographic information – Metadata - XML schema implementation for fundamental concepts*, 2016
- ISO 19123:2005 *Geographic information – Schema for coverage geometry and functions*
- ISO 19129:2009 *Geographic information – Imagery gridded and coverage data framework*
- ISO 19131:2007 *Geographic information – Data product specifications*
- ISO 19157:2013 *Geographic information – Data Quality*. As amended by Amendment 1, 2018
- ISO/IEC 19501-1 and 19505-2 *Information technology — Open Distributed Processing – Unified Modelling Language Version 2.4.1*
- netCDF *Network Common Data Form Unidata* – URL: www.unidata.ucar.edu/software/netcdf
- NGA 2021 *Recent Update to WGS 84 Reference Frame and NGA Transition to IGS ANTEX*, NGA Office of Geomatics / GNSS Division, St. Louis, National Geospatial-Intelligence Agency, 2021.
- NGA 2023 *WGS 84 (G2296) Terrestrial Reference Frame Realization*, Office of Geomatics, National Geospatial-Intelligence Agency, NGA-U-2023-02846, 2023.
- RFC 3986 *Uniform Resource Identifier (URI): Generic Syntax*. T. Berners-Lee, R. Fielding, L. Masinter. *Internet Standard 66*, IETF. URL: <http://www.ietf.org/rfc/rfc3986.txt> or <http://www.rfc-editor.org/info/std66>
- RFC 2141 *URN Syntax*. R. Moats. *IETF RFC 2141*, May 1997. URL: <http://www.rfc-editor.org/info/rfc2141>
- S-101 *IHO Electronic Navigational Chart Product Specification*, Edition 1.2.0 (in preparation)
- S-102 *IHO Bathymetric Surface Product Specification*, Edition 3.0 (in preparation)
- S-111 *IHO Surface Currents Product Specification*, **Edition 2.0.0 (in preparation)**
- XML Schema Part 2: *Datatypes*, Second Edition, W3C Recommendation, 28 October 2004, URL: <https://www.w3.org/TR/xmlschema-2/>

1.4 Terms, definitions and abbreviations

1.4.1 Terms and definitions

Terms and definitions have been taken from the normative references cited in Clause 1.3. Only those which are specific to this document have been included and modified where necessary.

accuracy

closeness of agreement between an observed value and the true value or a reference value accepted as true [ISO 19157, ISO 19116]

NOTE 1: A test result can be observations or measurements

NOTE 2: For positioning services, the test result is a measured value or set of values

NOTE 3: For observations and measurements, true values are not obtainable. In their place reference values which are accepted as true values are used

application schema

conceptual schema for data required by one or more applications [ISO 19101]

continuous coverage

coverage that returns different values for the same feature attribute at different direct positions within a single geometric object in its spatiotemporal domain [ISO 19123]

NOTE Although the spatiotemporal domain of a continuous coverage is ordinarily bounded in terms of its spatial extent, it can be subdivided into an infinite number of direct positions.

coordinate

one of a sequence of numbers designating the position of a point in N-dimensional space [ISO 19111]

coordinate reference system

coordinate system which is related to the real world by a datum [ISO 19111]

coverage

coverage that returns different values for the same feature attribute at different direct positions within a single spatial object, temporal object, or spatiotemporal object in its domain

NOTE: Although the domain of a continuous coverage is ordinarily bounded in terms of its spatial and/or temporal extent, it can be subdivided into an infinite number of direct positions [ISO 19123]

coverage

feature that acts as a **function** to return values from its **range** for any **direct position** within its spatial, temporal, or spatiotemporal **domain**

EXAMPLE: Examples include a raster **image**, polygon overlay, or digital elevation matrix.

NOTE: In other words, a **coverage** is a **feature** that has multiple values for each **attribute** type, where each **direct position** within the geometric representation of the **feature** has a single value for each **attribute** type [ISO 19123].

coverage geometry

Configuration of the **domain** of a **coverage** described in terms of **coordinates** [ISO 19123].

data product

dataset or **dataset series** that conforms to a data product specification

NOTE: The S-104 data product consists of metadata and one or more sets of water level height and trend [ISO 19131]

dataset

identifiable collection of data [ISO 19115]

NOTE A dataset may be a smaller grouping of data which, though limited by some constraint such as spatial extent or feature type, is located physically within a larger dataset. Theoretically, a dataset may be as small as a single feature or feature attribute contained within a larger dataset. A hardcopy map or chart may be considered a dataset.

dataset series

collection of datasets sharing the same product specification [ISO 19115]

datum

parameter or set of parameters that define the position of the origin, the scale, and the orientation of a coordinate system [ISO 19111, ISO 19116]

NOTE 1: A datum defines the position of the origin, the scale, and the orientation of the axes of a coordinate system

NOTE 2: A datum may be a geodetic datum, a vertical datum, an engineering datum, an image datum, or a temporal datum

direct position

position described by a single set of **coordinates** within a **coordinate reference system** [ISO 19107]

domain

well-defined set [ISO 19103]

NOTE: Domains are used to define the domain set and range set of operators and functions.

elevation

the altitude of the ground level of an object, measured from a specified vertical datum. [IHO S100 GFM]

feature

abstraction of real world phenomena [ISO 19101]

NOTE: A feature may occur as a type or an instance. Feature type or feature instance should be used when only one is meant.

feature attribute

characteristic of a feature

EXAMPLE 1: A **feature attribute** named *colour* may have an **attribute** value *green* which belongs to the **data type** *text*

EXAMPLE 2: A **feature attribute** named *length* may have an **attribute** value *82.4* which belongs to the **data type** *real*

NOTE 1: A **feature attribute** may occur as a **type** or an **instance**. **Feature attribute** type or **feature attribute** instance is used when only one is meant.

NOTE 2: A **feature attribute** type has a name, a **data type**, and a **domain** associated to it. A **feature attribute** instance has an **attribute** value taken from the **domain** of the **feature attribute** type.

NOTE 3: In a **Feature Catalogue**, a **feature attribute** may include a value **domain** but does not specify **attribute** values for **feature** instances.

[ISO 19101, ISO 19109, ISO 19110, ISO 19117]

height

distance of a point from a chosen reference surface measured upward along a line perpendicular to that surface. [ISO 19111:2006]

NOTE: Height is distinguished from elevation in that it is a directional measurement.

georectified

corrected for positional displacement with respect to the surface of the Earth [ISO 19115-2]

georeferenced Grid

grid for which cells can be located by the use of specific algorithms. See **ungeorectified grid**.

grid

network composed of a set of elements, or cells, whose vertices, or nodes, have defined positions within a coordinate system. See also **georeferenced grid**, **regular grid**, **ungeorectified grid**, **node**, and **grid point**. [ISO 19123]

NOTE 1: A rectangular grid has axes perpendicular to each other.

NOTE 2: A uniform rectangular grid has constant spacing in the X-direction and constant spacing in the Y-direction, although the two spacing values are not necessarily equal.

grid cell

element of a grid defined by its vertices, or **nodes**

grid coordinates

sequence of two or more numbers specifying a position with respect to its location on a **grid**

grid point

point located at the intersection of two or more **grid cells** in a **grid**. Also called a **node**. [ISO 19123]

gridded data

data whose attribute values are associated with positions on a grid coordinate system [ISO 19115-2]

positional accuracy

closeness of coordinate value to the true or accepted value in a specified reference system

NOTE: The term absolute accuracy is sometimes used for this concept to distinguish it from relative positional accuracy. Where the true coordinate value may not be perfectly known, accuracy is normally tested by comparison with available values that can best be accepted as true [ISO 19116]

record

finite, named collection of related items (objects or values) [ISO 19107]

NOTE: Logically, a record is a set of pairs <name,item>.

sequence

finite, ordered collection of related items (objects or values) that may be repeated

NOTE: Logically, a sequence is a set of pairs <item, offset>. LISP syntax, which delimits sequences with parentheses and separates elements in the sequence with commas, is used in this international standard [ISO 19107]

timestamp

value of time at which an object's state is measured and recorded [ISO 19132]

uncertainty

the interval (about a given value) that will contain the true value of the measurement at a specific confidence level [IHO S-44]

NOTE: Errors exist and are the differences between the measured value and the true value. Since the true value is never known it follows that the error itself cannot be known. Uncertainty is a statistical assessment of the likely magnitude of this error.

water level trend

change of water level at a given time, such as 'increasing', 'decreasing', or 'steady'.

When the average change of the water level over a one hour period is greater than or equal to a value set by the Producing Authority in metres it is considered "increasing". When it is less than or equal to - (value set by the Producing Authority in metres), it is "decreasing". When it is between the values set by the Producing Authority, it is "steady".

In areas of small water level range, for example Baltic Sea, use of "not available" is optional

ungeorectified grid

grid with non-uniform point spacing in any coordinate system. Includes triangular irregular networks (TINs) and those curvilinear coordinate grids whose node positions cannot be calculated analytically

vertical coordinate system

one-dimensional coordinate system used for gravity-related height or depth measurements [ISO 19111]

vertical datum

datum describing the relation of gravity-related heights or depths to the Earth

NOTE: In most cases the vertical datum will be related to mean sea level. Ellipsoidal heights are treated as related to a three-dimensional ellipsoidal coordinate system referenced to a geodetic datum. Vertical datums include sounding datums (used for hydrographic purposes), in which case the heights may be negative heights or depths [ISO 19111]

1.4.2 Abbreviations

API	Application Programming Interface
CRS	Coordinate Reference System
ECDIS	Electronic Chart Display Information System
EPSG	European Petroleum Survey Group
ENC	Electronic Navigational Chart
FC	Feature Catalogue
GIS	Geographic Information Systems
HDF	Hierarchical Data Format

IALA	International Association of Marine Aids to Navigation and Lighthouse Authorities
IHO	International Hydrographic Organization
IMO	International Maritime Organization
ISO	International Organization for Standardization
MRN	Maritime Resource Name
NetCDF	Network Common Data Form
PC	Portrayal Catalogue
SOLAS	International Convention for the Safety of Life at Sea
TIN	Triangulated Irregular Network
TWCWG	Tides, Water Level and Currents Working Group
UML	Unified Modelling Language
URN	Uniform Resource Name
UTC	Coordinated Universal Time
W3C	World Wide Web Consortium
XML	eXtensible Markup Language

1.4.3 Notation

In this document conceptual schemas are presented in the Unified Modelling Language (UML). Several model elements used in this schema are defined in ISO Standards developed by ISO TC 211, or in IHO S-100. In order to ensure that class names in the model are unique ISO TC/211 has adopted a convention of establishing a prefix to the names of classes that define the TC/211 defined UML package in which the UML class is defined. Since the IHO Standards and this Product Specification make use of classes derived directly from the ISO Standards this convention is also followed here. In the IHO Standards the class names are identified by the name of the Standard, such as "S100" as the prefix optionally followed by the bialpha prefix derived from ISO. For the classes defined in this Product Specification the prefix is "S104". In order to avoid having multiple classes instantiating the same root classes, the ISO classes and S-100 classes have been used where possible; however, a new instantiated class is required if there is a need to alter a class or relationship to prevent a reverse coupling between the model elements introduced in this document and those defined in S-100 or the ISO model.

Table 1.2 – Sources of externally defined UML classes

Prefix	Standard	Package
CI	ISO 19115-1	Citation and Responsible Party
CV	ISO 19123	Coverage Core & Discrete Coverages
DQ	ISO 19157	Data Quality Information
DS	ISO 19115-1	Metadata Application Information
EX	ISO 19115-1	Metadata Extent information
IF	ISO 19129	Imagery Gridded and Coverage Data Framework
LI	ISO 19115-1	Linage Information
MD	ISO 19115-1	Metadata entity set information
MI	ISO 19115-2	Metadata entity set imagery
S100	IHO S-100	IHO Standard for Hydrographic Data
SC	ISO 19111	Spatial Referencing by Coordinates
SD	ISO 19130	Sensor Data

1.5 Use of language

Within this document:

- “Must” indicates a mandatory requirement.
- “Should” indicates an optional requirement, that is the recommended process to be followed, but is not mandatory.
- “May” means “allowed to” or “could possibly”, and is not mandatory.

1.6 General data product description

NOTE: This clause provides general information regarding the data product.

Title:	Water Level Information for Surface Navigation
Abstract:	Encodes information and parameters for use in making a tidal and water level product.
Content:	Describes the tidal and water level data contained in the product. The specific content is defined by the Feature Catalogue and Schema.
Spatial Extent:	Description: Areas where tidal and water level information is available. East Bounding Longitude: 180 West Bounding Longitude: -180 North Bounding Latitude: 90 South Bounding Latitude: -90
Purpose:	The data shall be used to produce a dataset to be used for dynamic water level applications, including an ECDIS.

1.7 Data Product Specification metadata

NOTE: This information uniquely identifies this Product Specification and provides information about its creation and maintenance. For further information on dataset metadata see clause 12.

Title:	Water Level Information for Surface Navigation
S-100 Version:	5.2.0
S-104 Version:	2.0.0
Date:	2024-01-31
Language:	English
Classification:	Unclassified
Contact:	International Hydrographic Organization. 4 quai Antoine 1er B.P. 445 MC 98011 MONACO CEDEX Telephone: +377 93 10 81 00 Fax: + 377 93 10 81 40 Email: info@iho.int
Role:	Owner
URL:	https://registry.iho.int
Identifier:	S-104
Maintenance:	Changes to the Product Specification S-104 are coordinated by Tides, Water Level and Currents Working Group (TWCWG) of the IHO and made available via the IHO

Kommenterad [rmm3]: Update references to S-100 edition after S-100 edition freeze for S-104 2.0.0

Kommenterad [rmm4]: Has to be aligned to Edition 5.2.0 because of digital signatures

Kommenterad [rmm5]: Update references to Ed. 1.1.0 throughout

Publications web site. Maintenance of the Product Specification must conform to IHO Technical Resolution 2/2007 (revised 2010). This Specification will be a standing agenda item for TWCWG meetings with clarifications, revisions and new editions released as required.

1.7.1 IHO Product Specification maintenance

1.7.1.1 Introduction

Changes to S-104 will be released by the IHO as a New Edition, revision, or clarification.

1.7.1.2 New Edition

New Editions of S-104 introduce significant changes. *New Editions* enable new concepts, such as the ability to support new functions or applications, or the introduction of new constructs or data types. *New Editions* are likely to have a significant impact on either existing users or future users of S-104. All cumulative *revisions* and *clarifications* must be included with the release of approved New Editions.

1.7.1.3 Revision

Revisions are defined as substantive semantic changes to S-104. Typically, *revisions* will change S-104 to correct factual errors; introduce necessary changes that have become evident as a result of practical experience or changing circumstances. A *revision* must not be classified as a clarification. *Revisions* could have an impact on either existing users or future users of S-104. All cumulative *clarifications* must be included with the release of approved revisions.

Changes in a revision are minor and ensure backward compatibility with the previous versions within the same Edition. Newer revisions, for example, introduce new features and attributes. Within the same Edition, a dataset of one version could always be processed with a later version of the Feature and Portrayal Catalogues.

In most cases a new Feature Catalogue will result in a revision of S-104.

1.7.1.4 Clarification

Clarifications are non-substantive changes to S-104. Typically, *clarifications*: remove ambiguity; correct grammatical and spelling errors; amend or update cross references; and insert improved graphics. A *clarification* must not cause any substantive semantic change to S-104.

Changes in a *clarification* are minor and ensure backward compatibility with the previous versions within the same Edition.

1.7.1.5 Version numbers

The associated version control numbering to identify changes (n) to S-104 must be as follows:

New Editions denoted as **n.0.0**

Revisions denoted as n.**n**.0

Clarifications denoted as n.n.**n**

2 Specification Scopes

This Product Specification outlines the types of water level products from a national authority or authorised producer, to the end user. The data may be historical observation, real-time observation, astronomical prediction, analysis or hybrid method, hindcast or forecast models. Requirements for data and metadata are provided. The data product is a time series product, including series of water level heights relative to a vertical datum and the water level trend (rising, falling, etc.). The data product is a gridded data product—provision of water level information for a defined region as a surface, allowing any grid point to be queried as per a traditional single point.

Scope ID: Global
Level: 006- series
Level name: Water Level Dataset

3 Dataset Identification

Title: Water Level Information for Surface Navigation

Alternate Title: None

Abstract: This data product is a file containing water level data for a particular geographic region and set of times, along with the accompanying metadata describing the content, variables, applicable times, locations and structure of the data product. Water level data is the height of the water observed or mathematically-predicted. The data may consist of water level at a small set of points where observations or predictions are available or may consist of numerous points organised in a grid as from a hydrodynamic model forecast.

Topic Category: Producing Authority to choose the most appropriate from the list below:

Concept Name	ISO 19115-1 Topic Category Number	ISO 19115-1 Topic Category Code	Definition	Remarks
Elevation	006	elevation	Height above or below mean sea level Examples: altitude, bathymetry, digital elevation models, slope, derived products	Use for datasets intended for physical geography
Inland Waters	012	inlandWaters	Inland water features, drainage systems and their characteristics Examples: rivers and glaciers, salt lakes, water utilization plans, dams, currents, floods, water quality, hydrologic information	Use for datasets covering navigation on inland waterways
Oceans	014	oceans	Features and characteristics of salt water bodies (excluding inland waters) Examples: tides, tsunamis, coastal information, reefs	Use for datasets intended for coastal, offshore, or ocean navigation
Transportation	018	transportation	Means and aids for conveying persons and/or goods Examples: roads, airports/airstrips, shipping routes, tunnels, nautical charts, vehicle or vessel location, aeronautical charts, railways	Use for datasets intended for navigation (inland or maritime)

Geographic Description: Areas specific to water navigation

Spatial Resolution: The spatial resolution, or the spatial dimension of the earth covered by the size of a grid matrix cell (nominal ground sample)

distance), varies according to the model adopted by the producer.

- Purpose:** Water level data is intended to be used as stand-alone data or as a layer in an ENC.
- Language:** English
- Classification:** Data can be classified as one of the following:
 - 1) Unclassified;
 - 2) Restricted;
 - 3) Confidential;
 - 4) Secret;
 - 5) Top Secret;
 - 6) Sensitive but Unclassified;
 - 7) For Official Use Only;
 - 8) Protected; or
 - 9) Limited Distribution.
- Spatial Representation Type:** Coverage
- Point of Contact:** Producing Authority.
- Use Limitation:** Invalid over land. Some datasets may be designated as not for navigation.

4 Data Content and Structure

4.1 Introduction

This Section discusses the Application Schema, which is described in UML; the Feature Catalogue; dataset types, in which there is an extensive discussion of the water level data; and geometry.

Water level data consist of one basic geographic feature type:

1. A time series of water level height and trend relative to a vertical datum. An optional time attribute is also provided for use with certain types of water level information. The data can be represented for either a single point (that is, one geographic location) or for an array of points contained in a grid. Time and datum information are contained in the metadata.

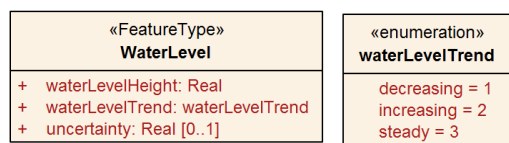

Figure 4-1 – Water level feature

4.2 Application Schema

The Application Schema is expressed in UML. The single feature type, **WaterLevel**, is depicted in Figure 4-1. The details of the Application Schema are given in Annex B, which also describes its relation to the conceptual model of coverage data described in ISO 19123 and S-100 Part 8.

4.3 Feature Catalogue

4.3.1 Introduction

The S-104 Feature Catalogue describes the feature types, information types, attributes, attribute values, associations and roles which may be used in the product. See Annex C – Feature Catalogue

Kommenterad [rmm6]: Remove waterLevelTime attribute?

Kommenterad [rmm7]: Replace, -waterLevelTime, or use waterlevelTime only for mini-grids?

The S-104 Feature Catalogue is available in an XML document which conforms to the S-100 XML Feature Catalogue Schema and can be downloaded from the IHO GI Registry website.

4.3.2 Feature types

4.3.2.1 Geographic

Geographic (geo) feature types form the principal content of S-104 and fully defined by their associated attributes.

4.3.2.2 Meta

Meta features contain information about other features within a data set. Information defined by meta features override the default metadata values defined by the data set descriptive records. Meta attribution on individual features overrides attribution on meta features.

4.3.3 Feature relationship

A feature relationship links instances of one feature type with instances of the same or a different feature type. There are three common types of feature relationship: Association, Aggregation and Composition. In S-104 there are no relationships used.

4.3.4 Attributes

S-100 defines attributes as either simple or complex. S-104 uses three types of simple attributes, listed in Table 4-1. There are no complex attributes.

Table 4-1 – Simple feature attribute types.

Type	Definition
Enumeration	A fixed list of valid identifiers of named literal values
Real	A signed Real (floating point) number consisting of a mantissa and an exponent
Date and Time	A DateTime is a combination of a date and a time type. Character encoding of a DateTime shall follow ISO 8601:1988 EXAMPLE 19850412T101530

4.3.5 Spatial quality

Spatial quality attributes (Figure 4-2) are encoded as horizontal and vertical uncertainty values. In S-100 Edition 5.0.0 they are encoded at the feature type level (see Figure 4-2 and Table 12-2), which means they apply uniformly to all **Water Level** feature instances in the dataset and uniformly to all locations (grid points or station locations).

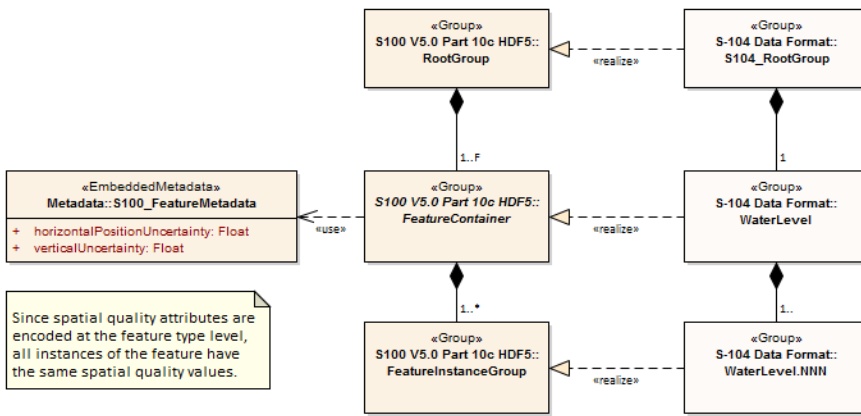

Since spatial quality attributes are encoded at the feature type level, all instances of the feature have the same spatial quality values.

Figure 4-2 – Spatial quality

Note that uncertainty in water levels pertains to the quality of data values, not to spatial quality as that term is used in S-100, and is encoded differently and at the instance level (see Table 10-2 and Clause 10.2.2.4).

Water levels are usually defined at one or more individual locations, so spatial quality applies to these locations.

NOTE: The **Spatial Quality** information type used in S-101 and other products is not used in this Edition of S-104.

4.4 Dataset types

Datasets for S-104 include one basic type of dataset: HDF5 files, which may contain gridded hydrodynamic model forecast fields.

4.5 Spatial Schema

4.5.1 Coverages

For an ECDIS, water level data are formatted as arrays of points contained in a regular grid. Further details on the data products are given in Section 10 – Data Product Format.

Water level data are categorised as follows, based on the data source:

1. Computed, observed, predicted, or forecasted values (for example hindcast or forecast data from hydrodynamic models) arranged in a regular grid.

The spatial structure used by S-104 is a regular grid, described by S100_IF_Grid (S-100 Edition 5.2.0, clause 8-7.5). The class S100_IF_Grid is a realization of CV_RectifiedGrid and CV_GridValuesMatrix from ISO 19123 and a component of ISO 19123 continuous quadrilateral grid coverages as realized by S100_IF_GridCoverage.

The types of water level data and their corresponding coverages are shown in Table 4-2.

Table 4-2 – Water level data types and their coverages

Type of Data	Spatial Structure	Coverage Type
Regularly-gridded data at one or more times	S100_IF_Grid	S100_IF_GridCoverage

Kommenterad [rmm8]: Revise to describe only regular grid forecasts
Also Hindcasts? Predictions?

The spatial representations in S-104 are encoded using the implementation specification in S-100 Part 10c, which realises S-100 Part 8 and ISO 19123 conceptual models. The relationships are depicted in Figure 4-3 below.

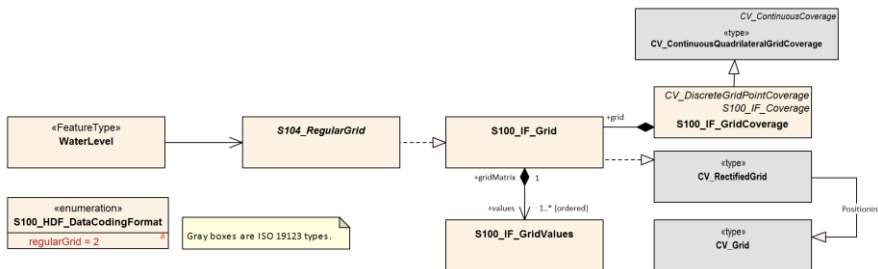

Figure 4-3 – Coverages and their realisation from S-100 Part 8 and ISO 19123

5 Coordinate Reference Systems (CRS)

To define the location of features using the S-100 Framework, one first needs to define a Coordinate Reference System (CRS). A Coordinate Reference System in two dimensions uses a coordinate pair, either X and Y for a Cartesian system or latitude and longitude for a geodetic/geographic system to define the location of a feature on a 2-D grid. However, if one wants to plot features in a 3-dimensional Coordinate Reference System, where we now want to include depths on a nautical chart or elevations on a map, one needs to assign the depth or elevation as the third component. For Cartesian systems, one would use X, Y, Z as the triplet or for geodetic/geographic systems, one would use latitude, longitude and height. The height can be the ellipsoid height or any of the other vertical references (see Vertical Reference System below). Geodetic/geographic coordinates are more intuitive for positioning and navigation applications on or near the Earth's surface while Cartesian coordinates are more appropriate if vectors are needed to accurately illustrate a graphical relationship between two or more points. If geodetic/geographic coordinates are specified, then the IHO recommends using the latest realisation of the World Geodetic System of 1984 (WGS 84).

5.1 Horizontal reference system

For products based on the S-100 Framework, including this Standard for S-104 products, the geodetic/geographic Coordinate Reference System must be of the form EPSG:xxxx (with WGS 84 as base datum). The generic form/code for the WGS 84 frame is EPSG:4326 while the latest and most widely adopted realisation of the WGS 84 reference frame as of 2022 was EPSG:9057. The full reference to EPSG can be found at <https://epsg.org> and other EPSG references for recent WGS 84 realisations are given below:

WGS 84 (generic)	EPSG:4326	
WGS 84(G2296)	(Not in EPSG registry at time of writing)	
WGS 84(G2139)	EPSG:9755	Valid epoch 2016:0
WGS 84(G1762)	EPSG:9057	Valid epoch 2005.0
WGS 84(G1674)	EPSG:9056	Valid epoch 2005.0
WGS 84(G1150)	EPSG:9055	Valid epoch 2001.0
WGS 84 / UTM Zone 1N to Zone 60N	EPSG:32601 – EPSG:32660	
WGS 84 / UTM Zone 1S to Zone 60S	EPSG:32701 – EPSG:32760	
WGS 84 / UPS North (E,N)	EPSG:5041	
WGS 84 / UPS South (E,N)	EPSG:5042	

Coordinate Reference System:	EPSG:9057 (WGS 84) or another reference system listed above
Datum:	WGS 84 defined by NGA
Projection:	None / UTM / UPS
Horizontal Units:	Decimal degrees / Easting and northing
Coordinate Reference System Registry:	EPSG Geodetic Parameter Registry
Date type (according to ISO 19115-1):	002 - publication
Responsible party:	International Association of Oil and Gas Producers (IOGP)

Producers of S-104 data must use the same projection as the underlying S-101 or S-102 dataset and should endeavour to use the same realisation.

5.2 Vertical reference system

For positioning and navigation applications, it is desirable to accurately plot depths, bathymetry, elevations and terrain on nautical charts and maps using one or more vertical reference systems. To do so, a vertical datum is defined and serves as a reference surface for vertical positions. Vertical datums come in three categories: 1) those based on Mean Sea Level (MSL); 2) tidal datums; and 3) 3-D datums (ellipsoid) which are realised through space-based systems such as GPS. Vertical datums can be regional (geoid, tidal, chart) or global (ellipsoid) in nature. The vertical axis of a vertical reference system is defined upwards (away from the Earth's centre) from its origin (EPSG code 6499) or downwards (EPSG code 6498) and is perpendicular to the horizontal surface where the observations or measurements are taken. As an example, a positive value for the level of water above the vertical datum in a vertical reference system with upward orientation (EPSG code 6499) means that the water level is above the vertical reference surface. For nautical charts, depths and tides are measured relative to a chart datum such as Lowest Astronomical Tide (LAT) or Mean Lower Low Water (MLLW).

Coordinate Reference System:	Vertical component of a 3-D reference system
Datum:	Chart, tidal, geoid, ellipsoid (WGS 84)
Projection:	None
Horizontal Units:	metres
Coordinate Reference System Registry:	EPSG Geodetic Parameter Registry
Date type (according to ISO 19115-1):	002 - publication
Responsible party (vertical datums):	National hydrographic and geodetic agencies

The vertical coordinate system is defined by three components. The first component defines the positive vertical direction (either an upward height or a downward depth). The second refers to the base or origin (that is, the zero value) of the vertical coordinate; if the base is a tidal datum, the specific datum is defined from either the S-100 list of vertical datums (for example LAT, MLLW, MSL, etc) or the EPSG list. Finally the specific datum number from the appropriate list is given. The components are summarised in Table 5-1.

Table 5-1 – Attributes describing the vertical coordinate system

Name	Remarks
Vertical Coordinate System	EPSG Code; Allowed Values <ul style="list-style-type: none"> • 6498 (Depth – Metres – Orientation Down) • 6499 (Height – Metres – Orientation Up)
Vertical Datum Reference	1 – S-100 vertical datum 2 – EPSG
Vertical Datum	If verticalDatumReference = 1 this is a value from S100_VerticalAndSoundingDatum If verticalDatumReference = 2 this is an EPSG code for vertical datum

For navigation, the vertical datum must be consistent with the CRS in the underlying S-101 and S-102 datasets. Conflicts such as differing datums or cases where a dataset uses multiple datums should be

resolved by discussion with the producer of the dataset(s) causing the conflict. (Splitting one or more of S-104 or another product into different datasets may be considered as a pathway to resolving such issues.)

5.3 Temporal reference system

The temporal reference system is the Gregorian calendar for date and UTC for time. Time is measured by reference to TM_Calendar dates and TM_Clock time in accordance with ISO 19108:2002, Temporal Schema Clause 5.4.4. A date variable will have the following 8-character format (ISO 8601): *yyyymmdd*. A time variable will have the following 7-character format: *hhmmssZ*. A date-time variable will have the following 16-character format: *yyyymmddThhmmssZ*.

6 Data Quality

6.1 Introduction

Quality of water level data for navigation consists of quality of the observed/predicted/forecast data, quality of the positional data and quality of the time stamp. Quality of the observed data depends on the accuracy of the water level gauges and their processing techniques, and is normally available in field survey reports or quality controlled analyses. Quality of predicted/forecast data depends on quality, timeliness, and spatial coverage of the input data as well as the mathematical techniques. Temporal accuracy for observational data is normally available in field survey reports or quality controlled analyses. Temporal accuracy for predicted/forecast data is normally described in technical reports.

6.1.1 Data quality metadata (informative)

The data quality information will list the following:

For Gridded data product:

- 1) Sigma confidence of predictions/model.

6.1.2 Data quality elements and data quality measures

Data quality allows users and user systems to assess fitness for use of the provided data. Data quality measures and the associated evaluation are reported as metadata of a data product. This metadata improves interoperability with other data products and provides usage by user groups that the data product was not originally intended for. The secondary users can make assessments of the data product usefulness in their application based on the reported data quality measures.

For S-104 the following Data Quality Elements have been included :

- Conformance to this Product Specification;
- Intended purpose of the data product;
- Completeness of the data product in terms of coverage;
- Logical Consistency;
- Positional Uncertainty and Accuracy;
- Thematic Accuracy;
- Temporal Quality;
- Aggregation measures;
- Validation checks or conformance checks including:
 - General tests for dataset integrity;
 - Specific tests for a specific data model.

Table 6-1 below indicates which of the data quality measures recommended in S-97 Part C have been identified as applicable to S-104. Columns 1-4 are taken as-is from S-97; the contents of column 5 are from S-97, annotated with whether the measure applies to S-104. Note that for attributes which allow fill values (see clause 10.2.2.2) the presence of a fill value is not counted as an error for the purposes of the data quality measures.

Kommenterad [rmm9]: To be updated for latest DQWG template and table (separate issue from limiting to reg grid).

Kommenterad [rmm10R9]: S100WG Chair – since DQWG updates to S-100 were postponed to Edition 6.0.0 at WG8 they cannot be used yet.

Table 6-1 – Quality measures applicable to S-104 (from S-97 Part C, clause 7)

Data quality measure	Definition	DQ measure / description	Evaluation scope	S-104 applicability
Completeness / Commission	Excess data present in a dataset, as described by the scope.	numberOfExcessItems / This data quality measure indicates the number of items in the dataset, that should not have been present in the dataset.	dataset/data set series	Yes (All S-100 based PS)
Completeness / Commission	Excess data present in a dataset, as described by the scope.	numberOfDuplicateFeatureInstances / This data quality measure indicates the total number of exact duplications of feature instances within the data.	dataset/data set series	Yes (All S-100 based PS)
Completeness / Omission	Data absent from the dataset, as described by the scope.	numberOfMissingItems / This data quality measure is an indicator that shows that a specific item is missing in the data.	dataset/data set series/spatial object type	Yes (All S-100 based PS) See clause 6.2 below
Logical Consistency / Conceptual Consistency	Adherence to the rules of a conceptual schema.	numberOfInvalidSurfaceOverlaps / This data quality measure is a count of the total number of erroneous overlaps within the data. Which surfaces may overlap and which must not is application dependent. Not all overlapping surfaces are necessarily erroneous.	spatial object / spatial object type	No (S104 does not define vector surface features) (Applies to PS with geometric surfaces)
Logical Consistency / Domain Consistency	Adherence of the values to the value domains.	numberOfNonconformantItems / This data quality measure is a count of all items in the dataset that are not in conformance with their value domain.	spatial object / spatial object type	Yes (All S-100 based PS)
Logical Consistency / Format Consistency	Degree to which data is stored in accordance with the physical structure of the dataset, as described by the scope	physicalStructureConflictsNumber / This data quality measure is a count of all items in the dataset that are stored in conflict with the physical structure of the dataset.	dataset/data set series	Yes (All S-100 based PS)
Logical Consistency / Topological Consistency	Correctness of the explicitly encoded topological characteristics of the dataset, as described by the scope.	rateOfFaultyPointCurveConnections / This data quality measure indicates the number of faulty link-node connections in relation to the number of supposed link-node connections. This data quality measure gives the erroneous point-curve connections in relation to the total number of point-curve connections.	spatial object / spatial object type	No (Applies only for PS with curves)

Data quality measure	Definition	DQ measure / description	Evaluation scope	S-104 applicability
Logical Consistency / Topological Consistency	Correctness of the explicitly encoded topological characteristics of the dataset, as described by the scope.	numberOfMissingConnectionsUndershoots / This data quality measure is a count of items in the dataset within the parameter tolerance that are mismatched due to undershoots.	spatial object / spatial object type	No (Applies only for PS with curves)
Logical Consistency / Topological Consistency	Correctness of the explicitly encoded topological characteristics of the dataset, as described by the scope.	numberOfMissingConnectionsOvershoots / This data quality measure is a count of items in the dataset within the parameter tolerance that are mismatched due to overshoots.	spatial object / spatial object type	No (Applies only for PS with curves)
Logical Consistency / Topological Consistency	Correctness of the explicitly encoded topological characteristics of the dataset, as described by the scope.	numberOfInvalidSlivers / This data quality measure is a count of all items in the dataset that are invalid sliver surfaces. A sliver is an unintended area that occurs when adjacent surfaces are not digitised properly. The borders of the adjacent surfaces may unintentionally gap or overlap to cause a topological error.	dataset / dataset series	No (Applies to PS with geometric surfaces)
Logical Consistency / Topological Consistency	Correctness of the explicitly encoded topological characteristics of the dataset, as described by the scope.	numberOfInvalidSelfIntersects / This data quality measure is a count of all items in the dataset that illegally intersect with themselves.	spatial object / spatial object type	No (Applies to PS with curves / geometric surfaces)
Logical Consistency / Topological Consistency	Correctness of the explicitly encoded topological characteristics of the dataset, as described by the scope.	numberOfInvalidSelfOverlap / This data quality measure is a count of all items in the dataset that illegally self-overlap.	spatial object / spatial object type	No (Applies to PS with curves / geometric surfaces)
Positional Accuracy / Absolute or External Accuracy	Closeness of reported coordinative values to values accepted as or being true.	Root Mean Square Error / Standard deviation, where the true value is not estimated from the observations but known a priori.	spatial object / spatial object type	No (S-104 allows only regular grids)
Positional Accuracy / Vertical Position Accuracy	Closeness of reported coordinative values to values accepted as or being true.	linearMapAccuracy2Sigma / Half length of the interval defined by an upper and lower limit in which the true value lies with probability 95%.	spatial object / spatial object type	No (S-104 allows only 2D grids)
Positional Accuracy / Horizontal Position Accuracy	Closeness of reported coordinative values to values accepted as or being true.	linearMapAccuracy2Sigma / Half length of the interval defined by an upper and lower limit in which the true value lies with probability 95%.	spatial object / spatial object type	No (S-104 allows only regular grids)

Data quality measure	Definition	DQ measure / description	Evaluation scope	S-104 applicability
Positional Accuracy / Gridded Data Position Accuracy	Closeness of reported coordinative values to values accepted as or being true.	Root mean square error of planimetry / Radius of a circle around the given point, in which the true value lies with probability P.	spatial object / spatial object type	Yes (Applies to PS with objects that have gridded coordinative values associated)
Temporal Quality / Temporal Consistency	Consistency with time.	Correctness of ordered events or sequences, if reported.	dataset/data set series/spatial object type	Yes, for time series features (Applies to PS with objects that have a time value associated)
Thematic Accuracy / Thematic Classification Correctness	Comparison of the classes assigned to features or their attributes to a universe of discourse.	<p>misclassificationRate / This data quality measure indicates the number of incorrectly classified features in relation to the number of features that are supposed to be there. [Adapted from ISO 19157]</p> <p>This is a RATE which is a ratio, and is expressed as a REAL number representing the rational fraction corresponding to the numerator and denominator of the ratio.</p> <p>For example, if there are 1 items that are classified incorrectly and there are 100 of the items in the dataset then the ratio is 1/100 and the reported rate = 0.01.</p>	dataset/data set series/spatial object type	Yes (All S-100 based PS)
Aggregation Measures / Aggregation Measures	In a data Product Specification, several requirements are set up for a product to conform to the Specification.	DataProductSpecificationPassed / This data quality measure is a boolean indicating that all requirements in the referred data Product Specification are fulfilled.	dataset/data set series/spatial object type	Yes (PS that require a complete pass of all elements of a dataset, dataset series, or spatial object types)
Aggregation Measures / Aggregation Measures	In a data Product Specification, several requirements are set up for a product to conform to the Specification.	DataProductSpecificationFailRate / This data quality measure is a number indicating the number of data Product Specification requirements that are not fulfilled by the current product/dataset in relation to the total number of data Product Specification requirements.	dataset/data set series/spatial object type	Yes (PS that require a complete pass of all elements of a dataset, dataset series, or spatial object types)

6.2 Additional components of data quality

A time series is complete when there is a value or a null indicator at every time in the series. A water level coverage data set is complete when the grid or point set coverage value matrix contains height

value or fill (missing) value for every vertex point defined in the grid, and when all of the mandatory associated metadata is provided. See Annex E – Validation Checks.

6.3 Assessment of data quality

The prescribed precision (see Annex A – Data Classification and Encoding Guide) of water level (0.01 m) is close to the perceived accuracy of the data.

Important factors in the quality of water level information for navigation consists of the quality of:

- The observed data;
- The predicted/forecast data;
- The positional data; and
- The time stamp.

Factors determining the accuracy of the data are shown in **Table 6-2**. Information of the quality of the components of the data is normally available in field survey reports, QC analyses, or other technical reports.

Table 6-2 - Data types and accuracy factors

Type of Data	Factors Influencing Accuracy
Observed water level	Accuracy of the sensors Processing techniques
Predicted/forecast Water level	Quality of input data Timeliness of input data Mathematical modelling techniques Accuracy of harmonic constants
Horizontal Position	Accuracy of geolocation techniques Model grid accuracy
Vertical Position	Accuracy of vertical datum
Time stamp	Sensor accuracy Data time tagging accuracy

Data quality measures for the entire data set are described in **Table 12-2**. These include *horizontalPositionUncertainty*, *verticalUncertainty*, and *timeUncertainty*. The additional data quality measure for uncertainty in *waterLevelHeight* is described in clause 10.2.2.4.

6.4 Validation checks

Validation checks are intended for production systems designed to produce S-104 Water Level Information datasets. Validation checks apply to either datasets (HDF5 dataset files) or exchange sets. Validation checks for S-104 datasets and exchange sets are defined in two locations:

- General validation checks for all S-100-based product specifications intended for use on navigation systems are defined in S-158.
- Product-specific validation checks are defined in Annex E of this document.

In addition, there are cross-product compatibility checks intended to verify suitability of combinations of products for use together on ECDIS. These checks will be defined in either S-98 or S-158.

Validation checks can be administered at any time during the production phase. They can also be applied downstream in the distribution and end user systems to test the conformance of a dataset to the format rules specified in S-100 Part 10c and the S-104 Product Specification.

For example, checks will be made for: inclusion of mandated variables; variable values being within accepted ranges; inclusion of optional values when required; matches between number of array

elements and array dimension specifications; timeliness of data; etc. Error severity may be, for example, that the dataset is unusable, that the dataset is of degraded utility but otherwise safe to use, or that the dataset has one or more small and inconsequential inconsistencies.

Fill values must be considered as allowed values for attributes which allow them (see clause 10.2.2.2), even though the fill value will be outside the allowed range in the Feature Catalogue.

Cross-product compatibility checks need to be administered to combinations of S-104 and S-102 or S-101 datasets. Their administration should be coordinated with producers of underlying S-101 or S-102 datasets.

7 Data Capture and Classification

The water level product contains data processed from sensors or derived from the output from mathematical models. In most cases, the data collected by the Producing Authority must be translated, sub-setted, reorganised, or otherwise processed to restructure into a usable data format.

7.1 Data sources for water levels

Water level data comes primarily from a few specific sources: observations; astronomical predictions; analyses; and forecast models. When such data are produced and quality-controlled by an approved Producing Authority (IHO Resolutions A6.3 & A6.9, S-62), they are suitable for inclusion in the water level data product.

NOTE: S-104 Edition 2.0.0 uses only data types which the water level adjustment algorithm described in S-98 can process.

Observational Data: Observational water level data comes initially from *in situ* sensors in the field (for example tide gauges deployed along a channel) and are monitored by the data collecting authority. After data acquisition, the data are quality controlled and stored by the Producing Authority. Some of the observed data may be available for distribution within minutes of being collected and are described as being 'in real time'. Other data may be days or years old, and are called historical data.

NOTE: Observational Data in S-104 Edition 2.0.0 must still conform to the regular grid format.

Astronomical Predictions: Astronomical predictions are produced when a sufficiently long time series of observed water level has been obtained and the data has been harmonically analysed by the Producing Authority to produce a set of amplitude and phase constants. The harmonic values can then be used to predict the astronomical component of the water level as a time series covering any desired time interval. Astronomical predictions can also be produced by other proven methods of tidal analysis. Data available for single stations or numerous stations must be arranged by the Producing Authority into a gridded field to conform to this edition of S-104.

Analysed and Hybrid Values: Analysed water level values may be derived from sea-surface topography, data assimilation, statistical correlations or other means. A hybrid method combines two of or more approaches.

Hindcast and Forecast Data: Hydrodynamic models numerically solve a set of fluid dynamic equations in two or three dimensions, and rely on observational data, including water levels and winds, to supply boundary conditions. Model grids may be either regular or irregular. Such models are often run several times per day, and can be a hindcast or a forecast. The hindcast is a model simulation that attempts to recreate present conditions by using the most recent observational data, while a forecast is a simulation made for many hours into the future using predicted winds, water levels, etc. The results are saved for a limited number of times, and are stored as arrays that derive from the model's grid. These models and methods are developed, run and monitored by the Producing Authority.

NOTE: Hindcast data are not used in S-104 Edition 2.0.0.

These descriptions are summarised in **Table 7-1**. (Note that the encoding format does not designate observation data as "historical" or "real-time".)

Kommenterad [rmm11]: Check for consistency with regular grid only types

Table 7-1 - Types of water level data, based on the source of the data

Type	Name	Description
4	Historical observation	Observation made hours, days, etc., in the past. Not used in S-104 Edition 2.0.0
2	Real-time observation	Observation no more than a few minutes old
3	Astronomical prediction	Value computed using harmonic analysis or other proven method of tidal analysis [IHO Res. 3/1919, as amended]
4	Analysis or hybrid method	Calculation by statistical or other indirect methods, or a combination of methods
5	Hindcast	Gridded data from a two- or three-dimensional dynamic simulation of past conditions using only observed data for boundary forcing, via statistical method or combination. Not used in S-104 Edition 2.0.0
6	Forecast	Gridded data from a two- or three-dimensional dynamic simulation of future conditions using predicted data for boundary forcing, via statistical method or combination

Kommenterad [rmm12]: Remove from navigation product

Kommenterad [rmm13]: Possible with regular grid?

Kommenterad [rmm14]: TBD for reg grid and WLA

Kommenterad [rmm15]: Not expected to be used for WLA

7.1.1 Determination of trend

When the average change of the water level over a defined period (time window) is greater than or equal to a threshold set by the Producing Authority it is considered “increasing”. When it is less than or equal to the negative of the threshold it is “decreasing”. When it is between the double-sided range (+/- threshold) set by the Producing Authority, it is “steady”.

The default time window over which the trend is calculated is 60 minutes. However, the 60 minutes window may not be ideal for all locations (for example, locations where there is no tide versus locations with strong tides) and producers may use a different window, in which case the window must be encoded in the *trendInterval* metadata attribute.

In areas of small water level range, for example Baltic Sea, use of “not available” is optional.

The parameters used by the Producing Authority in determining the trend are the threshold value and the time interval. These parameters can be encoded in the metadata attributes *waterLevelTrendThreshold* and *trendInterval* respectively. These attributes are allowed at the general metadata level and the Values group level. When encoded at the Values group level they apply only to the particular feature for which they are encoded and override the values encoded in the general metadata level.

Kommenterad [rmm16]: Does trend apply to regular grid data? Can it be computed at grid nodes?

Kommenterad [rmm17R16]: Yes – cf. NOAA. Retaining.

7.2 The production process

Nearly all available information on water level from the Producer must be reformatted to meet the standards of this Product Specification (Figure 10-1 – the S-104 format). This means (a) populating the carrier metadata block (clause 12.3) and values group attributes (Table 12-4) with the relevant metadata and (b) reorganizing the water level data when using the encoding rules (see Section 10 and Annex D – HDF5 Encoding for Gridded Data).

7.2.1 Metadata

Metadata is derivable from the information available from the approved Authority. The following variables will require additional processing:

- The bounding rectangle is computable from grid parameters. Note that the bounding box is encoded in both carrier metadata at the root group level and in the discovery metadata block (attribute *dataCoverage*) in the Exchange Catalogue, and must be the same in both places.
- Position uncertainties may be available from the approved Authority’s metadata.
- Water level uncertainty may be available from the prediction or forecast model, specification of the water level gauge or calculated from observations.

- If a previously issued data file is being cancelled or replaced, the *replacedData* and/or *dataReplacement* attributes in the Exchange Catalogue must be populated.
- The metadata file name in carrier metadata (attribute *metadata* in **Table 12-1**) must be populated with the empty string (equivalent to "" – without quotes – in many programming languages) because Edition 2.0.0 exchange sets do not use ISO metadata.

All mandatory metadata in carrier metadata (clause 12.3) must be populated with appropriate values. In cases where the attribute is mandatory but inapplicable, the appropriate fill or null value described in clause 12.3 must be used.

Similarly, when the Exchange Set is being compiled, all mandatory metadata or information fields in the discovery metadata and Exchange Catalogue (clauses 12.1 and 12.2) must be populated. In cases where the attribute is mandatory but inapplicable, or the value is unknown or not included in the relevant enumeration list, the appropriate fill or null value described must be used.

NOTE (informative): Running the S-100 level validation checks and product-specific validation checks (Annex E) should detect missing metadata, but as of the preparation of this document the checks are yet to be completely defined and automated, and visual checking of metadata may be necessary. The Tables in clauses 12.2 and 12.3 describe the mandatory requirements and allowed values.

7.2.2 Water Level Data

Observational water level and tidal water level predictions at a single location and gridded forecast data must normally be reformatted to fit the S-104 Standard. The following may require additional calculations:

- For gridded data. If a land mask array is included, the mask value is substituted into the gridded values as appropriate (see A-2).
- Time stamps must be encoded as UTC.

7.2.3 Validation

Dataset and Exchange Set validation tests must be passed before the Exchange Set is published.

For numeric attributes, the fill value will be outside the allowed range of values specified in the Feature Catalogue, if any. Similarly, for enumerations, the fill value will not be a member of the enumeration as listed in the Feature Catalogue. Validation checks for datasets must allow for the presence of fill values.

Validation must apply both the S-100 level validation checks defined in the S-100 validation specification (only those checks applicable to S-104 need be applied) and the product-specific validation checks provided as part of the S-104 Edition 2.0.0 Product Specification package.

7.2.4 Digital Signatures

Digital signatures are required for datasets and exchange sets intended for use on ECDIS. S-100 Part 15 describes the required signature algorithm and procedure for creating signatures. S-100 Part 17 describes where signatures must be provided. Additional guidance common to all datasets and exchange sets intended for ECDIS is being developed by the IHO. In the absence of this common guidance, the following guidance applies to S-104 datasets and exchange sets:

- The signature algorithm must be as specified in S-100 Part 15.
- In discovery metadata, the **S100_SE_SignatureOnData** element should be used to encapsulate digital signatures for datasets, with the *dataStatus* attribute set to *unencrypted* or *encrypted* according to whether the signature is for an unencrypted or encrypted HDF5 file.
- All resources in the exchange set must be signed, including any catalogue(s) and support files.
- At least one signature is required for each resource (dataset, catalogue, or support file) in the exchange set (the ECDIS will ignore unsigned resources or resources for which signature verification fails).
- Additional signatures may optionally be provided, or added downstream in the distribution chain, as provided for in S-100 Parts 17 and 15.

7.3 Guidance for chunking and compression (informative)

Chunking affects both dataset size and optimised data retrieval, the latter in the sense of how an ECDIS would most efficiently retrieve relevant chunks of a dataset when a user pans and zooms.

Product Specification developers may desire to assess typical profiles and volumes of data for their datasets and develop guidance for the use of chunking and compression in their data products. Common practice is provided below. Product teams should assess its applicability to their own products and use, omit, and adapt it accordingly.

The development of guidance on how to optimally and correctly do chunking and compression is ongoing; however, current best practice is:

- For gridded data with 2 dimensions, for example `dataCodingFormat = 2` (regular grids), choosing roughly-square rectangular chunk sizes will result in better performance when reading subsets of the data, and will probably result in better compression (one reason being that because NoData areas tend to be clustered together geographically, geographically-tiled chunks will compress out all those repetitive values).
- Producers may use "auto-chunking", where this functionality is available (for example, in the production toolset's HDF5 library). Auto-chunking will choose chunk sizes automatically.
- Choosing the right chunk sizes depends on the type of data and what the use of chunking is trying to accomplish. Auto chunking is more ideal for compression and is less ideal for time-critical access patterns.

Auto-chunking means different datasets may be chunked differently. Applications cannot expect a standardised chunk size and will have to handle whatever chunk sizes they encounter in datasets.

Data Producers should note experiences from preliminary testing:

- 2D arrays – Need to be chunked based on how the data is read. If applications need to hold the entire grid in memory, use no chunking; otherwise estimate a reasonable size for data extraction. It is probably better to have the chunking set a little smaller than to make it too big, for I/O purposes.
- 1D arrays – Do not chunk unless they are enormous (for S-104 this is not an issue since clause 11.2.1 limits datasets to well below the size where chunking matters).
- Given the relatively small sizes of datasets for S-104 (for example, 10 MB limit guidelines in clause 11.2.1) chunking will not be of great benefit in read performance for S-104.

Producers should determine the compression scheme that is optimal for their own use case, as needed.

7.4 Datasets in a series

Datasets in a time series (for example, 4X daily, 1X daily, etc.) may be distributed by any appropriate means, such as transfer to an accessible Internet service or via a licensed distribution channel.

Each release by the producer should be accompanied by an exchange catalogue and bear the appropriate producer digital signatures as specified in S-100 Part 17 and S-98.

Route monitoring applications require up-to-date water level information and periodic forecasts should be issued in a timely manner (meaning, a successor dataset should be released before the expiry of one full period after the starting date and time of its predecessor).

Multi-pack exchange sets containing multiple sequential datasets may also be prepared as determined necessary by the producer, for example, for uses other than route monitoring on ECDIS. For multi-packs a single exchange catalogue containing discovery metadata for all datasets should be prepared

7.5 Data use purpose

7.5.1 Datum requirements

Datasets intended for use in navigation must use the same CRS as the underlying S-102 and ENC¹. Particular care should be taken to ensure that the horizontal and vertical datum are the same as the underlying S-102 and ENC (with preference for S-101 over S-57). The epoch of realization should be included in this assessment.

NOTE: Conformant datums are a requirement for display on ECDIS, and water level adjustment as described in S-98 (see also Annex F).

7.5.2 Spatial type

All datasets intended for use in navigation on ECDIS must be issued as regular grids.

7.5.3 Suitability for navigation

Datasets may be marked for use in navigation if the Producer is able to consistently produce data of quality corresponding to the same zone of confidence as the underlying ENC. The Zones of Confidence are described in S-101 Annex A – Data Classification and Encoding Guide (attribute “category of zone of confidence in data” - CATZOC).

Alternatively, datasets may be marked for use in navigation if the Producer is able to consistently produce data along with their uncertainties.

Producers should note that combining S-104 data of lower accuracy with S-101 or S-102 data of higher accuracy may degrade the certainty of information available to the mariner.

7.5.4 Use purpose metadata

Datasets not intended for navigation purposes must have the discovery metadata attribute *notForNavigation* in the corresponding **S100_DatasetDiscoveryMetadata** block set to *true*.

Datasets intended for navigation must have the discovery metadata attribute *notForNavigation* in the corresponding **S100_DatasetDiscoveryMetadata** block set to *false*.

7.6 Compliance categories

Compliance categories are described in S-100 clause 4a-5.5. Datasets intended for use on ECDIS must meet the requirements for *category4* and the compliance category must be encoded accordingly..

7.7 Compliance with S-98

S-98 Edition 1.0.0 consists of a specification for visual interoperability (S-98 Main, S-98 Parts A/B/C/D, and S-98 Annexes A and B) and a specification for harmonised display of S-100 products on ECDIS (S-98 Annex C). The requirements for datasets to be compliant with each aspect of interoperability are described below. Compliance to this Edition of S-104 is a fundamental requirement and will not be explicitly listed.

7.7.1 Requirements for visual interoperability

S-104 Edition 2.0.0 datasets are intended only for use with water level adjustment as described in S-98 and therefore this Product Specification does not specify requirements for visual interoperability.

¹ There will usually be multiple underlying ENCs with different scale ranges, which will ideally use the same CRS and vertical datums. If not, the ENC Producer(s) should be consulted about possible ENC update plans and the appropriate ENC to which water level information should conform.

Kommenterad [rmm18]: Update with requirements for S-98 WLA

Kommenterad [rmm19]: Nav / WLA data must be category4

Kommenterad [rmm20]: Add WLA-compatibility requirements

7.7.2 Requirements for harmonised user experience

S-104 Edition 2.0.0 datasets are intended only for use with water level adjustment as described in S-98 and therefore this Product Specification does not specify requirements for achieving a harmonised user experience other than those required for water level adjustment functionality (clause 7.7.3).

7.7.3 Requirements for water level adjustment

- 1) The horizontal and vertical datums must be the same as the horizontal and vertical datums of the underlying S-101 (ENC) or S-102 (Bathymetry) dataset(s).
- 2) Requirements pertaining to maximum and minimum resolution of S-104 grids in relation to the underlying S-101 or S-102 datasets must be met. (As of the preparation of this document, these requirements are not yet defined.)
- 3) There must be no spatial overlap between S-104 datasets created by the same producer.
- 4) Temporal overlap is permitted only for datasets which are members of the same temporal series, when a forecast for a specific period is followed by a forecast for a later period. S-104 provides for a dataset naming convention that distinguishes successive datasets in a temporal series.
- 5) Other checks for cross-compatibility of S-101/S-102 and S-104 datasets should also be satisfied. These checks will be defined in S-98 and S-158.

8 Maintenance

8.1 Overview of dataset maintenance

Maintenance and Update Frequency: Water level is always moving, so more-or-less- continual revision or updating of the data is essential. For real-time observations, new values are periodically collected (for example every 6 minutes). For a forecast, the entire field of water levels is created one or more times per day. New issues of real-time observations or forecasts should be considered updates.

Table 8-1 summarises this information.

Table 8-1 – Typical update/revision intervals and related information for S-104 products produced by a single Producer.

Data Types	Update Interval	Number Of Spatial Locations	Number Of Time Values Per Location
Astronomical Predictions	1 year	100 to 1,000	52560 (10 minute data) or 8,760 (hourly data)
Model Forecasts	6 hr	100,000 to 1,000,000	1 to 24
Real-time Observations	0.1 hr	1 to 10	1 to 240

Kommenterad [rmm21]: Not for WLA

Kommenterad [rmm22R21]: Use for mini-grids?

NOTE: Population of the resource maintenance information in metadata will indicate to the ECDIS when new data can be expected to be available.

Data Source: Data is produced by the Producing Authority through the collection of observed values, predicting astronomical tides, or running analysis or hindcast/forecast. This data is typically quality-controlled and reformatted to conform to file size limitations and the S-104 Standard encoding.

Production Process: S-104 datasets, including the metadata and the coverages for water level, are updated by replacement of the entire data product. Producers routinely collect observational data and maintain an analysis and/or forecast capability. When new data becomes available (often several times per day), the data is reformatted and made available for dissemination.

8.1.1 Update of harmonic constants (informative)

Water level harmonic constant data are updated much less often than predictions, typically on an annual basis. Harmonic constants change their values if the environment changes (typically the bathymetry). Since this rarely happens an update of the harmonic constants has to be made only in rare occasions. If a long time series of level data is available, a statistical analysis of the harmonic constants can be made in order to use their standard deviations to decide if an update is really necessary, for example if their differences exceed three times the standard deviations.

Water level harmonic constant data should be updated only if their values differ from previous ones by a given amount (for example three times their standard deviations).

Since this Edition of S-104 does not include harmonic constants in datasets, updates to harmonic constants will affect S-104 datasets only as and when updated harmonic constants are used in generating S-104 datasets. Producers may use the *comment* attribute of dataset discovery blocks in the Exchange Catalogue to indicate which version of harmonic constants was used for the dataset.

8.2 Metadata related to dataset maintenance

8.2.1 Elements used in S-104

S-100 Edition 5.2.0 metadata related to maintenance that may be used in S-104 metadata consists of metadata elements specifying:

- The purpose (of issuing the dataset);
- The Edition number of the dataset;
- When its successor will be available;
- The issue date and time of the dataset; and
- The date of the metadata record for the dataset.

Some types of S-104 datasets use only some of these elements. Clauses 8.2.2 *ff.* provide guidance for selecting the values of these elements for the corresponding discovery metadata blocks in the Exchange Catalogue.

8.2.2 New datasets

8.2.2.1 Classification as new datasets

S-100 Part 17 (Table S100_Purpose) defines a new dataset as a “Brand new dataset” with a remark clarifying that “No data has previously been produced for this area”. The factors that should be considered in determining whether a dataset should be classified as a new dataset are:

- Whether any S-104 water level datasets are currently being produced for the region.
- Whether a new type of water level information (Table 7-1) is being made available. For example, if real-time observations are made available for a region where only astronomical predictions were formerly issued, the real-time dataset should be considered a new dataset.
- Changes to spatiotemporal representations:
 - Changes in the grid spacing for gridded data or interval for time series data should not be considered a new dataset.
 - Minor adjustments to spatial extent such as a small adjustment to a grid's boundaries or the addition of a new station to station-based data (DCFs 1 and 8) should not be considered new datasets.
 - Significant adjustments to spatial extent should be considered for classification as a new dataset.
 - The determination of whether an adjustment to spatial extent is minor or significant is left to the Producer.
- Additional factors: The effect on the end user, change of designation (“not for navigation” vs. “for navigation”), change of navigation purpose, effects on data distribution and data management on ECDIS.
- Local factors, such as the S-104 cell scheme used by the Producer.

8.2.2.2 Metadata for new datasets

Dataset discovery metadata (Clause 12.2) for a new dataset must be encoded as follows:

- *editionNumber* in dataset discovery metadata (clause 12.2.4) must be 1.
- *purpose* in dataset discovery metadata must be *newDataset*.

8.2.3 New Editions

8.2.3.1 Classification as New Edition

S-100 Part 17, clause 17-4.5 (S100_Purpose) states that a New Edition “Includes new information which has not been previously distributed by updates”.

New Editions of S-104 datasets are issued either when part or all the dataset is erroneous and must be replaced, or when better data become available. In either case, the dataset is replaced as a whole.

New Editions are not used for successor datasets (for example, when a forecast for a specific period is followed by a forecast for a later period). Instead, S-104 provides for a dataset naming convention that distinguishes successive datasets in a temporal series.

8.2.3.2 Metadata for new editions

For a New Edition, set:

- *purpose* = *newEdition*
- edition number: increment by 1

8.2.4 Cancellations

8.2.4.1 Classification as cancellation

S-100 Part 17, clause 17-4.5 (S100_Purpose) states that a cancellation “Indicates the dataset or Catalogue should no longer be used and can be deleted”.

S-104 datasets are cancelled only when a dataset or data sequence (such as a sequence of forecasts) is terminated. This might happen for various reasons, for example if Producers reorganise their S-104 cell scheming or replace one type of water level information by another.

Cancellation of a dataset in S-104 is interpreted consistently with S-100 Part 17, with additional conditions arising from the time-dependent nature of water level datasets. Cancellation of an S-104 dataset must be treated as described below:

- Water level information in the cancelled dataset for times beginning and after the effective date and time of cancellation must not be used. The effective date and time are the issue date and time in the discovery metadata for the cancellation record.
- Producers must ensure that date/time information for water level records in the dataset commences with the issue date and time.
- Water level information in the cancelled dataset for times preceding the effective date/time of cancellation may be used only in the absence of an uncanceled dataset covering the area and time in question.
- Cancellation of a dataset that is part of a sequence of forecasts also cancels preceding datasets in that sequence as described above. The sequence should be treated as terminated - there can be no successors to the cancelled dataset in the same sequence.
- There may be a successor sequence that starts with a new dataset. If there is, the fields *dataReplacement* and *replacedData* should be populated accordingly in the cancellation record.
- The retention, archiving or removal of cancelled datasets or sequences from the system shall be according to the common principles for retention, archiving or removal set forth in S-98 or other applicable documents.

8.2.4.2 Metadata for cancellation

S-104 uses the **fileless cancellation method** described in S-100 5.2.0 Part 17 clause 17-4.4.1. For a cancellation, set:

- *fileName* = *fileName* of the cancelled dataset (for a series, the *fileName* of the last dataset in the series)
- *purpose* = *cancellation*
- edition number = 0
- issue date and time = the issue date and time of the cancelled dataset
- digital signature = the digital signature of the cancelled dataset (for a series, the digital signature of the last dataset in the series)

Kommenterad [rmm23]: Pending resolution of data security questions

- *replacedData* = *true* if and only if the cancelled dataset or sequence is replaced by another dataset/sequence; otherwise *false*. This attribute must be populated for a cancellation.
- *dataReplacement* = cell name of the replacement dataset (if and only if the cancelled dataset/sequence is replaced by another dataset/sequence). This attribute must be populated when *replacedData=true*.

8.2.5 Other S100_Purpose values (informative)

S-104 does not use the *reissue*, *update* and *delta* values of the **S100_Purpose** enumeration.

S-100 Part 17, clause 17-4.5 (S100_Purpose) states that a re-issue “Includes all the updates applied to the original dataset up to the date of the re-issue. A re-issue does not contain any new information additional to that previously issued by updates”. Since S-104 does not include a format for dataset updates, S-104 datasets are not reissued. Corrections to datasets, if required, should be addressed by cancellation of the old dataset accompanied by a New Edition with the same name and an incremented Edition number.

S-100 Part 17, clause 17-4.5 (S100_Purpose) states that an update is for “Changing some information in an existing dataset”. S-104 does not provide for replacing part of a dataset; instead, if changing information is necessary, the whole dataset is replaced.

8.2.6 Maintenance of support files

The Edition number is 1 for the first issue of a support file for a particular dataset. In the event that the file is updated or replaced (for example for a correction) the Edition number is incremented by 1.

The Edition number for language packs changes if and only if the language pack file is updated.

8.2.7 Encoding update frequency

The encoding of information about when the next update to a dataset will be released (cf. clause 12.2.4 - *resourceMaintenance*) is mandatory for datasets that are updated or replaced monthly or more frequently.

The provision of this information for datasets that contain information updated less frequently than monthly (such as astronomical predictions when these are issued annually) is left to the discretion of the Producer, with the expectation that if it is not encoded in discovery metadata the expected release dates will be communicated to distributors and end-users by other means.

For datasets that are continually updated on a fixed cycle, timing information should be encoded as the interval from the issue date and time of the current dataset (that is, using the *userDefinedMaintenanceFrequency* sub-attribute - cf. S-100 Part 17, clause 17-4.9).

Data Producers or metadata compilers must consult S-100 clause 17-4.9 for the rules on encoding information about release timing.

9 Portrayal

The display of gridded water level data is controlled by the underlying ENC or bathymetry product because S-104 data is used to adjust depth and uncertainty values in those products. This edition of S-104 therefore does not provide a portrayal catalogue or describe symbology. Further, the only interoperability functionalities described by S-98 which apply to S-104 are those pertaining to water level adjustment. These functionalities are described in S-98 Annex C.

NOTE 1: Specification of the algorithm for adjustment of bathymetry data or ENC feature data is outside the scope of this Product Specification. It is described in S-98.

NOTE 2: There are no specifications for the display of a water surface from gridded data as a distinct layer in this Product Specification Edition.

10 Data Product Format (Encoding)

10.1 Introduction

The water level data products must be encoded using one of the listed formats. The structure of the data product is discussed in the next section. There is only one format allowed to encode data.

Format: HDF5 for water level height and trend data
Character Set: MD_CharacterSetCode (ISO19115-1) should be set to utf8
Specification: S-100 profile of HDF5

10.2 HDF5 product structure for time series and gridded data

The key idea at the core of the structure is this: The organisation of the information is substantially the same for each of the various types of data, but the information itself will be interpreted differently.

10.2.1 Data type definition

HDF5 will be used for all water level data types.

Format Name: HDF5
Character Set: MD_CharacterSetCode (ISO 19115-1)
Specification: S-100 profile of HDF5

This product format is designed to be flexible enough to apply to water level values in the form of: (a) data at one or more times for one or more individual, fixed stations, organised by time or station; (b) regularly-gridded data for one or more times; (c) ungeorectified gridded data for one or more times; and (d) TIN data. This approach contains, for each type, data in a similar format but which is interpreted differently. Since each type of data will be interpreted differently, the type of data must be identified by the variable *dataCodingFormat*, as shown in **Table 10-1**. (The letters in parentheses in the second column reference the types listed earlier in this paragraph.)

Table 10-1 – S-104 data types and values of the variable *dataCodingFormat* (see S-100 Edition 5.0.0, Table 10c-23)

dataCodingFormat	Type of Data
2	Regularly-gridded data at one or more times - type (b)

Kommenterad [rmm24]: Only this for WLA

For the use of HDF5, the following key concepts (S-100 Part 10c, clause 10c-5.1) are important:

- *File* - a contiguous string of bytes in a computer store (memory, disk, etc), and the bytes represent zero or more objects of the model;
- *Group* - a collection of objects (including groups);
- *Dataset* - a multidimensional array of data elements with attributes and other metadata;
- *Dataspace* - a description of the dimensions of a multidimensional array;
- *Datatype* - a description of a specific class of data element including its storage layout as a pattern of bits;
- *Attribute* - a named data value associated with a group, dataset, or named datatype;
- *Property List* - a collection of parameters (some permanent and some transient) controlling options in the library;
- *Link* - the way objects are connected.

In addition, a dataset may have one, two, or more dimensions, and each element in the dataset may be a compound. That is, each element may itself be an array of possibly different datatypes (float, integer, string, etc).

For all data types, the product structure in HDF5 includes: (a) a metadata block; which is followed by (b) one or more Groups which contain the actual water level data. The water level information is saved in arrays that hold either gridded data or a time series.

10.2.2 Product structure

The structure of the data product follows the form given in S-100 Part 10c – HDF5 Data Model and File Format. The general structure is given in **Figure 10-1** and is the same as the generic structure described in S-100 with elements not used in S-104 omitted.

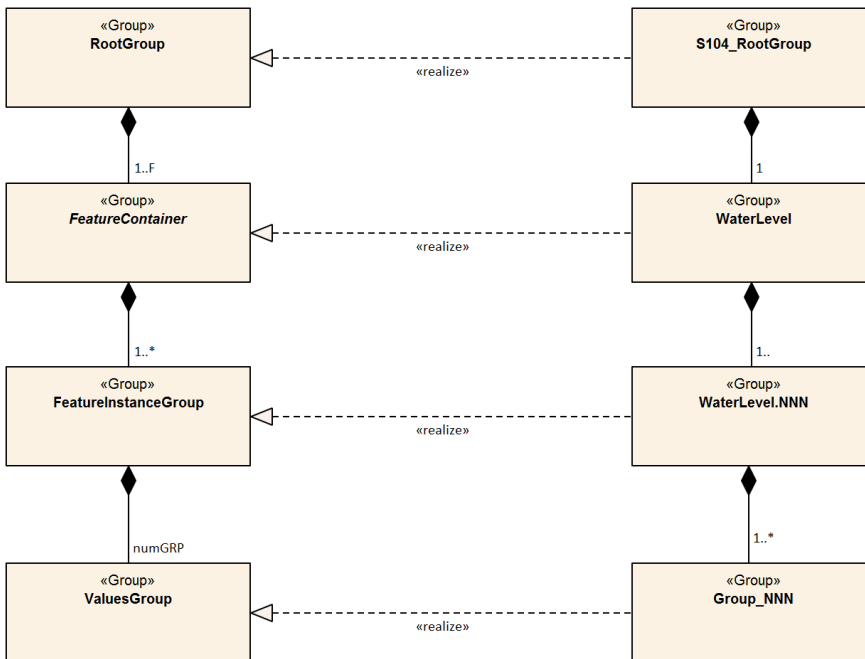

Figure 10-1 - Outline of the data file structure for S-104 data files, showing the realisation of S-104 structure from the generic structure described in S-100 (see S-100 Part 10c, Figure 10c-7). Note that there are four levels from top to bottom

In **Figure 10-1** there are four levels:

Level 1: At the top level lies the Root Group, and it contains the Root Metadata (**Table 12-1**) and two subsidiary groups. The Root Metadata applies to all S-100 type products.

Level 2: The next Level contains the Feature Information Group and the Feature Container Group. The Feature Information Group contains two datasets: the featureCode, which has the name of the S-100 feature (here WaterLevel); and the feature information dataset (WaterLevel) which contains a compound array with eight parameters for each S-100 feature attribute (height, trend, and time). The Feature Container Group contains the Feature Type Metadata (**Table 12-2**) and one or more Feature Instance Groups. The Feature Type Metadata is common to all water level products.

Level 3: This contains one or more Feature Instances. A feature instance is, for example, a time series of gridded data for a single region; or a time series of astronomical predictions for a set of stations.

Level 4: This contains the actual data for the feature. S-104 uses only the Values Group. The Positioning group in S-100 is not needed for regular grids and is therefore not used in this edition of S-104.

The basic structure of the S-104 data product is shown in **Table 10-2**. Levels refer to HDF5 structuring. (C.f. S-100 Part 10c, Figure 10c-9). Naming in each box below header line is as follows: **Generic name;** S-100 or S-104 name; and (*HDF5 type*) group, attribute or attribute list, or dataset.

Table 10-2 – Overview of an S-104 data product

Kommenterad [rmm25]: Review and remove elements not used for reg grids

LEVEL 1 (ROOT) CONTENT	LEVEL 2 CONTENT	LEVEL 3 CONTENT	LEVEL 4 CONTENT
General Metadata (see Table 12-1) (<i>h5_attribute</i>)			
Feature Codes Group_F (<i>h5_group</i>)	Feature Type Name WaterLevel (<i>h5_dataset</i>)		
	Feature Type Codes featureCode (<i>h5_dataset</i>)		
Feature Type WaterLevel (<i>h5_group</i>)	Feature Type Metadata (see Table 12-2) (<i>h5_attribute</i>)		
	Horz. & vert. Axis Names axisNames (<i>h5_dataset</i>)		
	First Feature Instance WaterLevel.01 (<i>h5_group</i>)	Feature Instance Metadata (see Table 12-3) (<i>h5_attribute</i>)	
		Uncertainty Data uncertainty (<i>h5_dataset</i>)	
		First data group Group_001 (<i>h5_group</i>)	Time Attribute timePoint (<i>h5_attribute</i>)
			Height+trend Array values (<i>h5_dataset</i>)
		Second data group Group_002 (<i>h5_group</i>)	Time Attribute timePoint (<i>h5_attribute</i>)
			Height+trend Array values (<i>h5_dataset</i>)
		Third data group Group_003 (<i>h5_group</i>)	Time Attribute timePoint (<i>h5_attribute</i>)
			Height+trend Array values (<i>h5_dataset</i>)
	Second Feature Instance WaterLevel.02 (<i>h5_group</i>)	Feature Instance Metadata (see Table 12-3) (<i>h5_attribute</i>)	

The following clauses explain entries in **Table 10-2** in more detail.

10.2.2.1 Root group

The Root group contains the Feature Codes group, the Feature Type group, and the simple attributes shown in **Table 12-1**.

10.2.2.2 Feature type codes (Group_F)

This group specifies the S-100 feature to which the data applies. The group has no attributes and consists of two components:

featureCode – a dataset with the name(s) of the S-100 feature(s) contained in the data product. For S-104, the dataset has a single element, the string “WaterLevel”.

WaterLevel – this is a dataset with the name contained in the **featureCode** dataset. The dataset contains a one-dimensional compound array of length 3 (one for each of the three water level attributes: height, trend, and time). Each of the three elements of string values has 8 values, as shown in **Table 10-3**.

NOTE: Values provided in **Table 10-3** are required.

Table 10-3 – Contents of the one-dimensional compound array (length = 3, compound elements = 8) WaterLevel. All values are strings

N	Name	Explanation	Attribute 1	Attribute 2	Attribute 3
1	code	Camel Case Name	waterLevelHeight	waterLevelTrend	uncertainty
2	name	Plain text	Water Level Height	Water Level Trend	Uncertainty
3	uom.name	Units of Measurement	metres		metres
4	fillValue	Denotes missing data	-9999.00	0	-1.00
5	datatype	HDF5 datatype	H5T_FLOAT	H5T_ENUM	H5T_FLOAT
6	lower	Lower bound on attribute	-99.99		0.00
7	upper	Upper bound on attribute	99.99		99.99
8	closure	Open or Closed data interval. See S100_IntervalType in S-100 Part 1	closedInterval		closedInterval

Kommenterad [rmm26]: Adding uncertainty was requested by CA, but the exact details have not been discussed. Should it be a single value as currently drafted, a factor (% of height), or should S104 provide for both? NB: The attribute "uncertainty" is already defined in the GI registry, as are "uncertaintyFixed" and "uncertaintyVariable".

The values in this array must be consistent with the corresponding entries in the Feature Catalogue except that the *uncertainty* attribute is encoded in this array if and only if the uncertainty attribute is included in the values record.

10.2.2.3 Type group (WaterLevel)

This group contains a dataset called *axisNames* and one or more instances of the single feature **WaterLevel**. A single instance may contain a gridded forecast at multiple hours, or a set of time series predictions or observations at several stations. This group has the simple attributes shown in **Table 12-2**. For S-104, *axisNames* consists of two elements, the strings 'longitude' and 'latitude' (EPSG:4326 axis names). The contents of the *axisNames* array must be exactly the same as the axis names used by the appropriate registry entry for the coordinate system specified in the metadata; for EPSG, the axis names in the corresponding EPSG Registry entry must be used.

10.2.2.4 Instance group (WaterLevel.nn)

This group contains a single instance of the feature (see clause 10.2.2.3). The groups are numbered from 01 to 99. This group has the simple attributes shown in **Table 12-3**, as well as the (water level, trend, and time) values groups, the (conditional) positioning group, and a dataset called 'uncertainty'.

Uncertainty Dataset – The (optional) uncertainty data is contained in a compound HDF5 dataset named 'uncertainty'. There is a name and an uncertainty value for water level height, which is *waterLevelHeight*. The units of height uncertainty are metres. The default, denoting a missing value, is -1.0. The values in the uncertainty dataset are overridden for individual grid points by the *uncertainty* component of the values record when it is populated by a non-fill value.

10.2.2.5 Value groups (Group_nnn)

These groups each contain an attribute (the date-time stamp), and the compound data arrays containing water level height and trend, and optionally uncertainty. These groups have the simple attributes shown in **Table 12-4**. These components are explained below.

Date-Time Stamp - The date-time stamp is an attribute named *timePoint* with a single (string) value. For gridded data the time stamp is the time of validity for all points in the grid.

Value Arrays - The height, trend and local uncertainty values (*waterLevelHeight*, *waterLevelTrend* and *uncertainty*) are stored in arrays named *values*, with a prescribed number of rows (*numROWS*) and, if two-dimensional, columns (*numCOLS*).

For a regular grid (*dataCodingFormat* = 2), the height, trend and (local) uncertainty values will be for each point in the grid, the data array values is two-dimensional, and the time for all points in the grid is given by the date-time stamp.

10.2.2.6 Conditional geography group (Positioning)

The group named **Positioning** contains all the locations (longitude and latitude values) that have associated data values. This group has no attributes.

For *dataCodingFormat* = 2 (regular grid), location data for grid points can be computed from the grid origin and number of grid points in each dimension, which are encoded as HDF5 attributes. The attribute *numPOS* is not needed since the grid data is stored as a two-dimensional array with the number of rows and columns given by the numbers of grid points in each dimension. See S-100 Part 10c, clause 10c-9.3 for more information.

NOTE: the variable names in this Group (longitude, latitude) must match in case and spelling those in *axisNames*.

Table 10-4 – Values of *numPOS* for the group *Positioning*

Data Coding Format	Data Type	Location Data	Array Size: Value of <i>numPOS</i>
2	Regular grid	(Not applicable)	(Not applicable)

10.2.2.7 Summary of generalised dimensions

To summarise, for regular grids *numPOS* is inapplicable and X and Y positions of individual grid points are not stored. There are only data Groups containing water level data, which are stored in two-dimensional arrays of size *numROWS* by *numCOLS*. The total number of data Groups is *numGRP*.

The four variables that determine the array sizes (*numROWS*, *numCOLS*, *numPOS*, and *numGRP*) are given in Table 10-5.

Table 10-5 – The array dimensions used in the data product

Data Coding Format	Data Type	Positioning	Data Values		
		<i>numPOS</i>	<i>numCOLS</i>	<i>numROWS</i>	<i>numGRP</i>
2	Regular Grid	(not used)	<i>numPointsLongitudinal</i>	<i>numPointsLatitudinal</i>	<i>numberOfTimes</i>

10.2.2.8 Mandatory naming conventions

The following group and dataset names are mandatory in S-100: 'Group_F', 'featureCode', and (for S-104) 'WaterLevel', 'axisNames', 'Positioning', (for S-104) 'WaterLevel.nn', and 'Group_nnn' (n is an integer from 0 to 9). Attribute names shown in clause 12.3 are also mandatory.

10.2.2.9 Summary of product structure

For regularly gridded data, the water level array is two dimensional, with dimensions *numPointsLongitudinal* and *numPointsLatitudinal*. These attributes are part of feature instance metadata described in Table 12-3 and S-100 Part 10c, Table 10c-12. By knowing the grid origin and the grid spacings, the position of every point in the grid can be computed by simple formulae.

The remaining groups each contain a title, a date-time value (attribute *timePoint*), and the water level array. The title can be used to identify each individual station with time-series data. For *dataCodingFormat* = 2, the date-time is for the entire grid. The water level array is two dimensional, with a number of columns (*numCOLS*) and rows (*numROWS*). For a grid, the water value will be for each point in the grid.

The format allows features to be encoded only with uniform time intervals.

- For uniform time intervals, the time interval is encoded as an attribute of the Values group. In this case, the date-time of individual records is omitted from the water level array.

The groups are numbered 1, 2, etc, up to the maximum number of groups, *numGRP*. For regular grids (*dataCodingFormat* = 2), the number of groups is the number of time records.

Kommenterad [rmm27]: Only this for RG

Kommenterad [rmm28]: No positioning needed for RG

The overall structure of the water level data product is created by assembling the data and metadata. The product structure is compliant with the HDF5 data architecture, which allows multi-dimensional arrays of data to be grouped with metadata. The format of the data product (cf. Figure 10-1) described above is portrayed in Figure 10.2. The Carrier Metadata is discussed in clause 12.3 (Tables 12-3 – 12-5), and the Values group attributes are discussed in clause 12.3 (Table 12-4).

NOTE: The name of each Group is the 'Group_nnn', where nnn is numbered from 1 to numGRP.

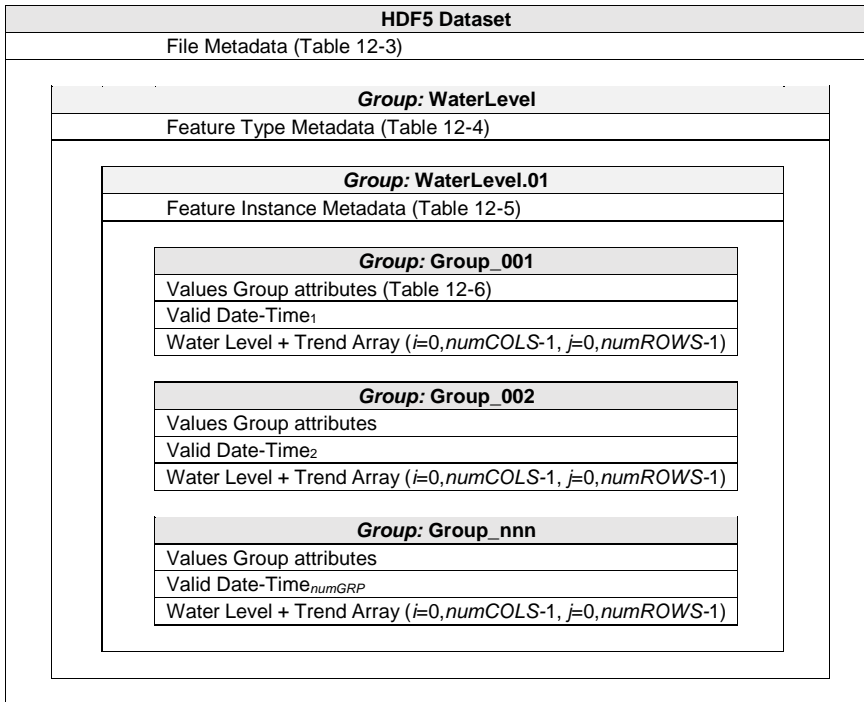

Figure 10.2 - Schematic of the S-104 HDF5 data product structure. The four parameters numPOS, numCOLS, numROWS, and numGRP are explained in Table 10-5.

Valid Date-Time_{1,2,...,numGRP} have specific meanings and encodings for dataCodingFormat = 2 (see Table 12-6).

10.2.2.10 Digital Certification Block

Information here is used to certify the validity or integrity of the data.

This Edition does not provide for inclusion of certificates or digital signatures within the HDF5 file. When necessary, certificates and digital signatures must be provided for the HDF5 file as a whole, using the mechanisms described in S-100 Parts 15 and 17.

10.3 Sample HDF5 encoding

The product structure has been designed for compatibility with the HDF5 capabilities. The HDF5 encoding of the data set is discussed in Annex D – Sample HDF5 Encoding.

11 Data Product Delivery

11.1 Introduction

This Section describes how the water level data product is to be packaged by the Producer.

Due to the cost of transmitting data via the internet, it is desirable to limit file size and updating frequency whenever possible. Considerations here are the size of each transfer as well as the total volume of data transferred over time (the latter particularly applies to datasets which are issued daily or more frequently, such as forecasts). The following recommendations are therefore proposed:

- 1) Each exchange data file, as created by the Producer and after compression, is recommended to be limited to 10 MB.
- 2) The “cell scheming” (geographic extents covered) for datasets, especially datasets which are issued frequently (for example, daily or more frequent forecasts) should be determined so as to reduce the transfer of unnecessary data (information not needed for route planning or monitoring within reasonable time windows). It is recommended that cell scheming and grid density take into account the navigation purposes defined in S100_NavigationPurpose, reproduced below:
 - a. port – For port and near shore operations
 - b. transit – For coast and planning purposes
 - c. overview – For ocean crossing and planning purposes.

S-100 Part 15, clause 15-5.2 allows one data compression scheme: Zip (note that this may not provide a significant reduction due to internal compression applied within the HDF file). In addition, the file may be encrypted.

Updating of files typically means issuing a new forecast, or disseminating the latest observed water level for a specific geographic region. This may occur several times per day. Therefore, all files must contain a date-time of issuance of the product. Because of the potentially high frequency (that is, hourly or less) availability of new datasets, the ECDIS system may need to check for new data at a similar frequency. The “resource maintenance” information in external metadata and “delivery interval” in internal metadata should therefore be populated whenever possible.

11.2 HDF5 dataset packaging

The HDF5-formatted datasets are packaged with metadata and an Exchange Catalogue, and then combined into an Exchange Set. HDF5 files for time series or gridded water level data may require internet transmission, since they change several or more times a day.

11.2.1 Exchange Sets

Datasets, or data products, produced by the Producer consist of packages (such as ZIP archives or files organised within a file system folder/directory structure), containing both the Exchange Catalogue and one or more data products (of possibly different S-100 types), with each product covering a specific geographic region and specific period of time (**Figure 11-1**). The Exchange Catalogue lists the products and contains the discovery metadata. Support files may also be included in the package.

The name of the Exchange Set must be derived from the catalogue identifier, which in turn must be globally unique. See clause 12.2.2 for the rules determining how the catalogue identifier is constructed. An extension appropriate to the packaging method must be suffixed. For example:

- If the catalogue identifier is 104ABCDXYZ_1_20_20210420 and the Exchange set is packaged as a Zip file, the name of the Zip file must be 104ABCDXYZ_1_20_20210420.zip or 104ABCDXYZ_1_20_20210420.ZIP.
- If the catalogue identifier is 104ABCDXYZ_1_20_20210420 and the Exchange Set is distributed as a folder on compact disc media, the folder name must be 104ABCDXYZ_1_20_20210420.

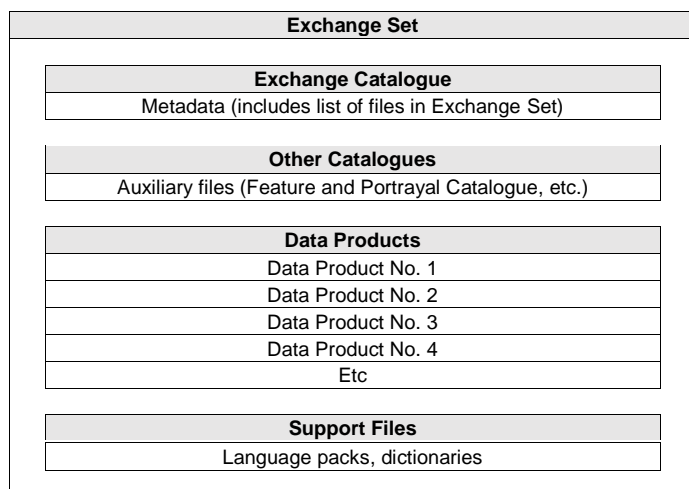

Figure 11-1 – Schematic diagram of the Exchange Set.

The Exchange Set size is limited to 10 MB. The size of datasets (HDF5 data files) can vary widely, depending on the data. Using the sample HDF5 files (see Annex D), a file containing, along with metadata, a single water level height array and a single water level trend array, each with 100,000 grid points would have a size of approximately 0.21 Mbytes. Exchange files may be compressed using the DEFLATE compression algorithm commonly used in ZIP archives (cf. S-100 Part 15, clause 15-5.2). Doing so can reduce file size by 80% or more.

11.2.1.1 Exchange Set structure

The structure of an S-104 Exchange Set must be according to the structure described below, which is based on S-100 Part 17, clause 17-4.2. The S-104 Exchange Set structure is depicted in **Figure 11-2**.

- 1) All content must be placed inside a top root folder named S100_ROOT. This is the only top level root folder in an Exchange Set containing only S-100 products.
- 2) The S100_ROOT folder must contain a subfolder for S-104 which holds content specific to S-104.
- 3) An S-104 Exchange Set must contain an Exchange Set Catalogue, CATALOG.XML, its digital signature CATALOG.SIGN and may contain any number of S-104 conformant dataset files and Catalogue files.
- 4) The S-104 subfolder must contain subfolders for the component dataset files (DATASET_FILES) and Catalogues (CATALOGUES) as required:
 - a. The DATASET_FILES subfolder is required if and only if the Exchange Set contains an S-104 HDF5 dataset.
 - b. The CATALOGUES subfolder is required if and only if the Exchange Set contains a Feature Catalogue. (This Edition of S-104 does not include Interoperability or Portrayal Catalogues.)
- 5) The DATASET_FILES folder must contain a subfolder named according to the Producer Code.
- 6) Individual data files must be placed under the Producer subfolder, either directly in the Producer folder, or within a lower-level subfolder hierarchy. Individual data files may be optionally placed in their own subfolders or grouped with other data files.
- 7) An Exchange Set may carry Feature and Portrayal Catalogues in different versions, which should also be grouped together in the CATALOGUES folder.
- 8) If a Portrayal Catalogue is included in the Exchange Set, it may be packaged as either a ZIP archive containing all Portrayal Catalogue files, or a filesystem structure of folders and files. The structure of Portrayal Catalogues is described in S-100 Part 9, clause 9-13.2 and guidance on packaging Portrayal Catalogues is provided in clause **Fel! Hittar inte referenskälla..**

- 9) Except for the signature of the Exchange Catalogue file (CATALOG.XML), which is in the CATALOG.SIGN file, all digital signatures are included within their corresponding resource metadata records in CATALOG.XML.
- 10) Dataset and Catalogue file and/or folder names should be such as to avoid inadvertent overwriting of files.
- 11) Digital signatures are required for Exchange Sets and datasets intended for navigation on ECDIS. All resources included within an Exchange Set intended for navigation, including support files and catalogues, must be signed (S-100 Part 17).
- 12) It is not necessary for an Exchange Set to contain more than one build of a Feature Catalogue for the same version of a Product Specification.
- 13) Inclusion of the dictionary of enumerations in any particular Exchange Set is optional, since it will be the same for all datasets from all Producers. For similar reasons, inclusion of the Feature Catalogue in any particular Exchange Set is optional. Producers may distribute dummy Exchange Sets containing only the Feature Catalogue and enumerations dictionary, when any of them is updated or when a new version of the Product Specification is released. Validation checks should ensure that these files are present on the system if they are not included in any particular Exchange Set.

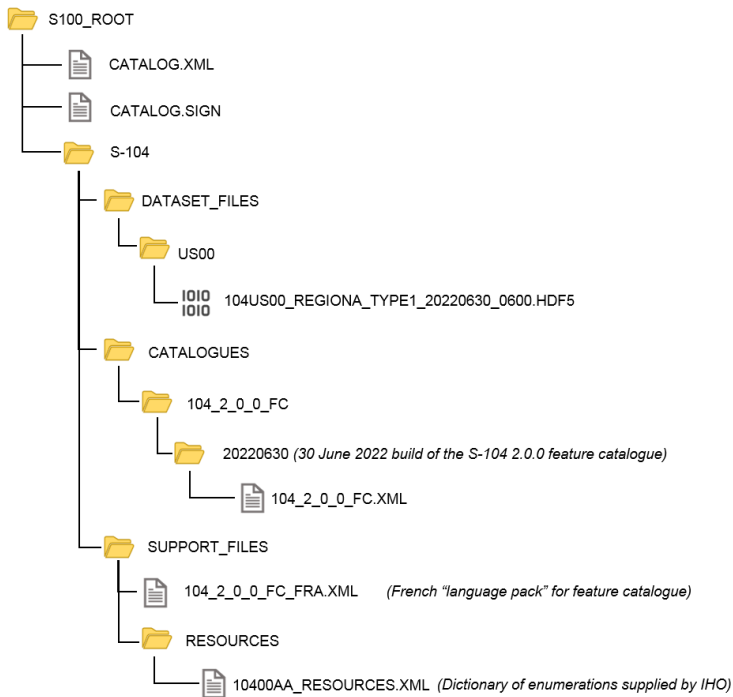

Figure 11-2 – Typical Exchange Set structure

General guidelines for Exchange Set structure are included in S-100 Part 17.

Note that the names and locations of files are coded within the CATALOG.XML or Portrayal Catalogue files, and therefore files and folders should not be renamed or relocated by Producers or end-user systems unless these references can be updated. Portrayal and Feature Catalogues can be relocated to a common system location if their internal structure is maintained.

11.2.2 Exchange Catalogue

The Exchange Catalogue which is in XML format acts as the table of contents for the Exchange Set. The catalogue file of the Exchange Set must be named CATALOG.XML (as specified in S-100 Part 17); no other file in the Exchange Set may have the same name. The contents of the Exchange Catalogue are described in Section 12.

The Exchange Catalogue Schemas for S-104 are the same as for S-100 and may be obtained from the IHO S-100 Schema server: <https://schemas.s100dev.net>. The S-104 Exchange Catalogue uses an additional product-specific constraints file implementing product-specific restrictions, which is also available from the same site. Use of the additional product-specific constraints file is optional; developers may implement the constraints using any convenient method.

11.2.3 Dataset file naming

The dataset file contains both metadata and one or more sets of height and trend arrays (see Section 10 – Data Product Format). The dataset name must begin with the three-character Product Specification number, followed by the four-character Producer Code (CCCC)². Thus water level files begin with the seven-character string '104CCCC'.

The characters between this string and the extension are nominally unrestricted in S-100 and S-97 Edition 1.1.0. However, S-104 restricts the “unrestricted” characters as follows:

- Alphabetic characters in the “Latin alphabet; that is, A-Z and a-z;
- Numeric characters; that is, the characters 0-9;
- The hyphen and underscore characters (“-“ and “_”).

The “unrestricted” characters may be used to denote geographical region, valid time, source of the data, version numbers, and/or any other relevant information. Characters may be lower or upper case³. For real-time and forecast data, it is recommended that the dateTime of the first record be part of the dataset name, to help distinguish the most recent files.

The filename extension for HDF5 (.h5) must be used to denote the file format.

The total length of the file name shall be no more than 64 characters, including the extension.

EXAMPLE 1: 104US00_CHES_TYPE1_20210630_0600.h5 for observational data (see clause 12.3.5, Table 12.10) produced by NOAA for Chesapeake Bay (CHES), observations beginning from 06:00 UTC on 30 June 2021.

EXAMPLE 2: 104US00_ches_dcf8_20190703T00Z.h5 for a dataset produced by NOAA containing data for NOAA fixed stations in the Chesapeake Bay (ches) organised stationwise (dcf8) beginning from midnight at the beginning of 3 July 2019.

Each Producer should adopt a naming scheme that is consistent across its entire S-104 product line. While the examples above are hypothetical, they illustrate how the principles of this clause can be applied by Producers.

11.2.3.1 Dataset MRN (informative)

The dataset file name may be mapped to an MRN as follows:

```
urn:mrn:iho:s104:1:1:0:<cccc>:<region>:<type>:<dtg>
```

where:

- The first part “urn:mrn:iho:s104” is common to all dataset URNs for S-104;
- The Product Specification version is represented by the “1:1:0” part;
- <cccc> represents the 4-character Producer Code;

² Producer Codes may be obtained from the IHO Producer Code Register in the IHO GI Registry. The four-character S-100 “Alpha” codes must be used.

³ Exceptions: (1) Producer Codes must use the same case as the IHO Producer Code Register. (2) A name component taken from an external Specification, must follow the rules in that Specification (for example, “20190703T00Z” for a time component in ISO 8601 basic format, not “20190703t00z”).

- <region> represents the geographical region;
- <type> represents the data coding format, for example “type2” for regular grids;
- <dtg> represents the date/time component in the name.

This is an interim rule pending definition of an “S-100-wide” rule for MRNs and will be superseded by the “S-100-wide” rule when it is published.

11.2.4 Support files

Only the following types of support files are allowed in S-104:

- Optional 'language packs' for Feature Catalogues. Each language pack contains a translation of the Feature Catalogue into a specified language.
- Dictionary resource files listing the allowed values and codes of enumerations. There will generally be a single dictionary file for each version of the Product Specification (corrections, if any, will be issued through the usual mechanism for corrections). Inclusion of the dictionary resource file in Exchange Sets is optional, since the Internet location is standardised and manufacturers are permitted to obtain it by other means and install it in an application-specific location.

11.2.5 Support file naming

11.2.5.1 General

Support file names are subject to the same naming rules as dataset file names (clause 11.2.3), except that the extension is determined by the support file format.

This clause covers names of language packs and enumeration dictionaries, which are the only support files allowed in this Edition of S-104. Producers who discover a need for other types of support files should conform to the general rule above and consult the TWCWG as necessary.

11.2.5.2 Names of language packs

If a language pack created by a data Producer for the S-104 Feature Catalogue is included, it must have the standard 7-character “104CCCC” prefix and the same base name as the standard IHO-issued Feature Catalogue with the 3-letter ISO 639-2/T language code suffixed. The language codes must be exactly those in the S-100 codelist for languages (**S100_MD_LanguageCode**, which can be found in the S-100 Edition 5.0.0 Schema distribution). The file extension must be “.XML”.

NOTE: A language pack issued by the IHO for the IHO Feature Catalogue will use the IHO Producer Code.

EXAMPLE: The language pack for Italian translations issued by the data Producer with code “IT01” of the Feature Catalogue named 104_1_1_0_FC.XML is named 104IT01_104_1_1_0_FC_ita.XML.

11.2.5.3 Names of enumeration dictionaries

Enumeration dictionaries are supplied by IHO as part of this Product Specification and should not be renamed.

NOTE (informative): Substitute or extended enumeration dictionaries may be developed if translations are needed. Producers who desire to provide translations of enumeration dictionaries with S-104 Exchange Sets should consult with the TWCWG.

12 Metadata

12.1 Introduction

For information exchange, there are several categories of metadata required:

- Metadata about the overall Exchange Set and Catalogue;
- Discovery metadata about each of the datasets contained in the Catalogue; and
- Discovery metadata about the support files that make up the package.

The discovery metadata classes have numerous attributes which enable important information about the datasets and accompanying support files to be examined without the need to process the data, for example, decrypt, decompress, load, etc.

Feature Catalogues can be included in the Exchange Set in support of the datasets. If included, discovery metadata about the Catalogues must also be provided.

NOTE: S-104 datasets do not reference support files. The only support files allowed in the Exchange Set are "language packs" for Feature Catalogues and enumeration dictionaries, and these are not referenced from within the HDF5 datasets.

Discovery metadata for each HDF5 dataset is given in an XML block within the Exchange Set Catalogue file, and can be accessed without opening the HDF5 file. In addition to discovery metadata, S-104 also provides for carrier metadata that is embedded within the HDF5 file, which provides information needed to process and display the data. Discovery metadata is described in clause 12.2; carrier metadata in clause 12.3.

This Section defines the mandatory and optional metadata needed for S-104. In some cases (if provided by the Producer or Exchange Set packager) the metadata may be repeated in a language other than English. See S-100 Part 17, clauses 17-4.6 – 17-4.8 for guidance on encoding of metadata in languages other than English.

12.1.1 Realisation of Exchange Set components and metadata classes (informative)

The realization of S-104 Exchange Set components and metadata classes from ISO 19115-1 and ISO 19115-3 is the same as in S-100 Part 17, depicted in Figure 12-1. The Figure depicts, from left to right:

- (i) The relevant ISO data exchange structural classes;
- (ii) The relevant ISO metadata classes for metadata for exchange;
- (iii) S-100 structure classes representing the S-100/S-104 Exchange Set components;
- (iv) The relevant S-100/S-104 Exchange Set metadata classes.

Note that the only support files in S-104 are language packs or enumeration dictionaries, represented by **S100_SupportFile**. The corresponding metadata blocks are represented by **S100_SupportFileDiscoveryMetadata** elements.

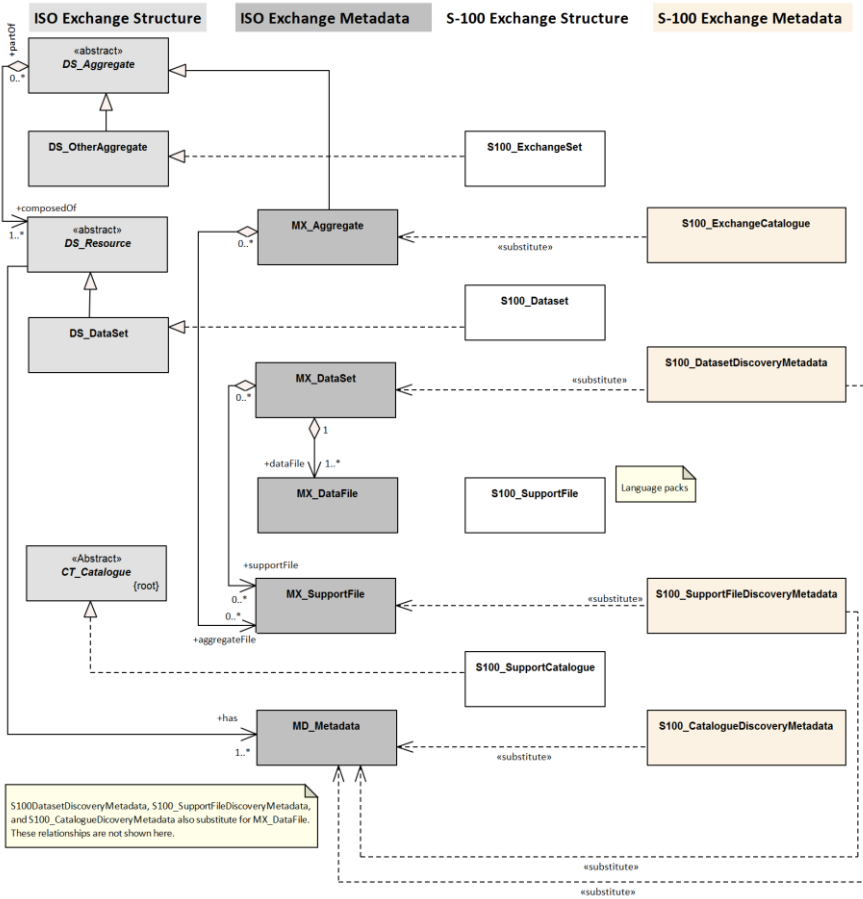

Figure 12-1 – Realisation of the Exchange Set classes (S-100 Part 17, Figure 17-1 with relationships not used in S-104 omitted)

12.1.2 Exchange Set components and related metadata

Figure 12-2 depicts the relationships of Exchange Set “core” elements (datasets and Feature/Portrayal Catalogues) and Exchange Set metadata. This Figure is derived from S-100 Part 17, Figure 17-2. Relationships not applicable to S-104 have been omitted (for example, the link between datasets and support files in S-100 Figure 17-2, because S-104 datasets do not reference support files). Note also that the link between **S100_Dataset** and **S100_CatalogueMetadata** is implicit by means of the S-104 version to which the Feature Catalogue, Portrayal Catalogue and dataset conform, which must have the same Edition and revision components.

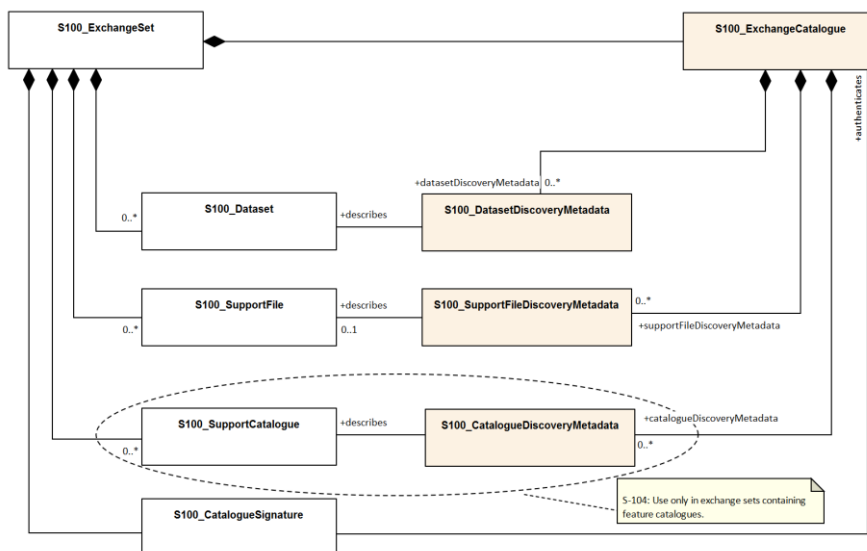

Figure 12-2 – Components and associated metadata for the S-104 Exchange Set (S-100 Part 17, Figure 17-2 with relationships not used by S-104 omitted)

The rules governing the presence and roles of the exchange set components depicted in **Figure 12-2** are given below.

- 1) Every Exchange Set must contain an Exchange Catalogue, represented by **S100_ExchangeCatalogue** in **Figure 12-2**.
- 2) Dataset discovery metadata (**S100_DatasetDiscoveryMetadata**) must be provided in the Exchange Catalogue for each S-104 dataset in the Exchange Set.
- 3) Catalogue metadata (**S100_CatalogueDiscoveryMetadata**) must be provided in the Exchange Catalogue for any Feature and Portrayal Catalogues included in the Exchange Set.
- 4) The only support files allowed are language packs and enumeration dictionaries (both represented by **S100_SupportFile**). Their inclusion in Exchange Sets is optional.
- 5) Producers must not include ISO metadata files to convey information for ECDIS application processing, since processing these files is not an ECDIS requirement. All information necessary for ECDIS processing must be in CATALOG.XML
- 6) Language packs are described in S-100 Part 18 and provide translations of Feature Catalogues.
- 7) If a language pack is included, a support file discovery metadata block (**S100_SupportFileDiscoveryMetadata**) describing the file must be included in the Exchange Catalogue.
- 8) A signature file for the Exchange Catalogue must also be included in the Exchange Set (**S100_CatalogueSignature**).

Since S-104 does not add product-specific metadata attributes, the S-100 metadata classes and Schema are used in S-104 Exchange Sets without extension. The constraints S-104 impose on generic S-100 metadata are described in the documentation Tables in clause 12.2.

NOTE: The distribution package implements the additional S-104 constraints on metadata attributes (and many of the S-100 constraints) as Schematron rules in files available from the IHO Schema server. Implementers may substitute any implementation method to apply or check constraints instead of using Schematron-capable processing software.

The tangible representations of the structure classes in **Figure 12-2** within actual Exchange Sets are the digital files or folders containing the Exchange Set, dataset(s), Catalogue(s), and support files. The tangible representations of their roles as depicted in **Figure 12-2** are the inclusion of the respective

components within the Exchange Set. Documentation tables for the structure classes are not provided since the Exchange Set structure is described in clause 11.2.1.

The metadata classes in **Figure 12-2** are represented by XML files or XML blocks and are documented in clause 12.2.

12.2 Discovery metadata

An outline of the overall concept of an S-104 Exchange Set for the interchange of geospatial data and its relevant metadata is explained in clauses 11.2.1 and 12.1.1. The place of metadata in the Exchange Set is summarised in clause 12.1.2.

Figure 12-3 depicts the structure of the Exchange Catalogue and its component discovery metadata blocks. The structure is the same as in S-100 Part 17.

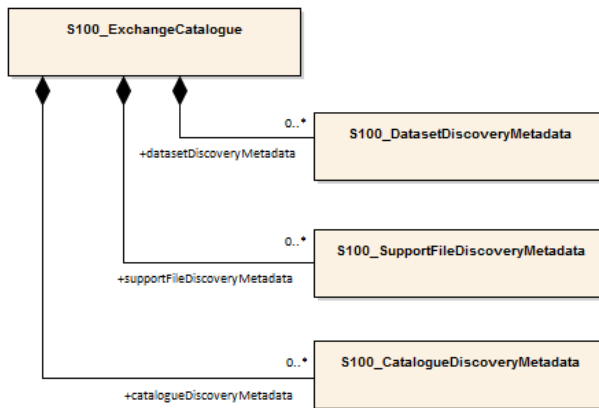

Figure 12-3 – Relationship between Exchange Catalogue, discovery metadata, and dataset (from S-100 Part 17, Figure 17-6)

The detailed structure of the S-104 Exchange Catalogue is depicted in **Figure 12-4**. This Figure is derived from S-100 Part 17, Figure 17-7, with the following restrictions:

- Elements that are optional in the generic S-100 catalogue model but not used in S-104 are not shown; for example, the *updateNumber* and *updateApplicationDate* attributes in the dataset discovery class are not used in S-104.
- Constraints that are specific to S-104 are summarised in a diagram note. Details about constraints are provided in the documentation tables following the diagram.

In S-104 Edition 2.0.0 the only catalogues allowed are Feature Catalogues.

The language used for the metadata is English.

Time reference for all data will be UTC.

All water level values to be given in metres (up to two decimal places for real values).

More detailed information about the various classes and textual descriptions of the constraints are in the Tables in clauses 12.2.1 – 12.2.30 following **Figure 12-4**. Differences from generic S-100 metadata are emphasized for developer convenience in **bold** text.

Page intentionally left blank

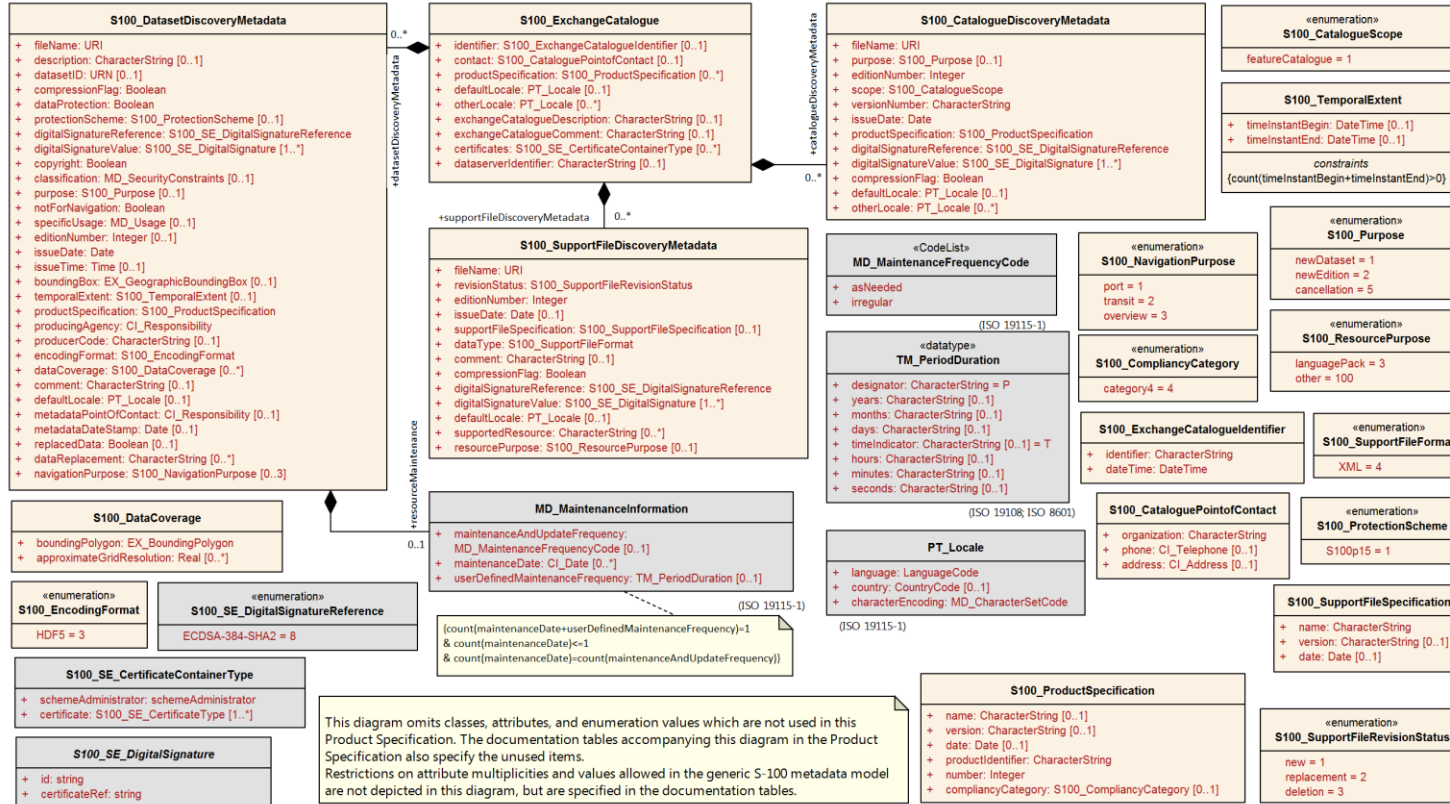

This diagram omits classes, attributes, and enumeration values which are not used in this Product Specification. The documentation tables accompanying this diagram in the Product Specification also specify the unused items. Restrictions on attribute multiplicities and values allowed in the generic S-100 metadata model are not depicted in this diagram, but are specified in the documentation tables.

Figure 12-4 – Details of Exchange Set Catalogue classes. Based on S-100 Part 17, Figure 17-7

12.2.1 S100_ExchangeCatalogue

Each Exchange Set has a single S100_ExchangeCatalogue which is an XML file that contains meta information for the data in the Exchange Set. S-104 restricts the S-100 class as described in the Remarks column.

Role Name	Name	Description	Mult	Type	Remarks
Class	S100_ExchangeCatalogue	An Exchange Catalogue contains the discovery metadata about the exchange datasets and support files	-	-	The optional S-100 attributes <i>identifier</i>, <i>contact</i>, and <i>productSpecification</i> are mandatory in S-104
Attribute	identifier	Uniquely identifies this Exchange Catalogue	1	S100_ExchangeCatalogueIdentifier	Mandatory in S-104
Attribute	contact	Details about the issuer of this Exchange Catalogue	1	S100_CataloguePointOfContact	Mandatory in S-104
Attribute	productSpecification	Details about the Product Specifications used for the datasets contained in the Exchange Catalogue	1	S100_ProductSpecification	Mandatory in S-104
Attribute	defaultLocale	Default language and character set used for all metadata records in this Exchange Catalogue	0..1	PT_Locale	Default is English and UTF-8
Attribute	otherLocale	Other languages and character sets used for the localized metadata records in this Exchange Catalogue	0..*	PT_Locale	Required if any localized entries are present in the Exchange Catalogue
Attribute	exchangeCatalogueDescription	Description of what the Exchange Catalogue contains	0..1	CharacterString	
Attribute	exchangeCatalogueComment	Any additional Information	0..1	CharacterString	
Attribute	certificates	Signed public key certificates referred to by digital signatures in the Exchange Set	0..*	S100_SE_CertificateContainerType	Content defined in S-100 Part 15. All certificates used, except the SA root certificate (installed separately by the implementing system) shall be included
Attribute	dataServerIdentifier	Identifies the data server for the permit	0..1	CharacterString	
Role	datasetDiscoveryMetadata	Exchange Catalogues may include or reference discovery metadata for the datasets in the Exchange Set	0..*	Aggregation S100_DatasetDiscoveryMetadata	
Role	catalogueDiscoveryMetadata	Metadata for Catalogue	0..*	Aggregation S100_CatalogueDiscoveryMetadata	Metadata for the Feature, Portrayal and Interoperability Catalogues, if any
Role	supportFileDiscoveryMetadata	Exchange Catalogues may include or reference discovery metadata for the support files in the Exchange Set	0..*	Aggregation S100_SupportFileDiscoveryMetadata	The only support files allowed in S-104 are enumeration dictionaries and language packs for Feature Catalogues

12.2.2 S100_ExchangeCatalogueIdentifier

S-104 uses **S100_ExchangeCatalogueIdentifier** without modification.

Role Name	Name	Description	Mult	Type	Remarks
Class	S100_ExchangeCatalogueIdentifier	An Exchange Catalogue contains the discovery metadata about the exchange datasets and support files	-	-	The concatenation of identifier and dateTime form the unique name
Attribute	identifier	Uniquely identifies this Exchange Catalogue	1	CharacterString	See Note 1 for the naming convention
Attribute	dateTime	Creation date and time of the Exchange Catalogue, including time zone	1	DateTime	Format: yyyy-mm-ddThh:mm:ssZ

NOTE 1: Use the file name component of the dataset according to the convention in clause 11.2.3. For example, if the dataset file is named 104ABCDXYZ_1_20_20210420.h5 the metadata identifier should be 104ABCDXYZ_1_20_20210420. In the event of an Exchange Set containing multiple datasets, use the name of the dataset of largest extent with a "+N" suffix (without quotes), where N is the number of additional datasets in the Exchange Set. If the Exchange Set contains only Feature and/or Portrayal Catalogues, use 104ABCD+N where "ABCD" is the 4-character code of the producer of the Feature or Portrayal Catalogue.

12.2.3 S100_CataloguePointofContact

S-104 uses **S100_CataloguePointOfContact** without modification.

Role Name	Name	Description	Mult	Type	Remarks
Class	S100_CataloguePointOfContact	Contact details of the issuer of this Exchange Catalogue	-	-	-
Attribute	organization	The organization distributing this Exchange Catalogue	1	CharacterString	This could be an individual producer, value added reseller, etc
Attribute	phone	The phone number of the Organization	0..1	CI_Telephone	
Attribute	address	The address of the Organization	0..1	CI_Address	

12.2.4 S100_DatasetDiscoveryMetadata

Data in the Discovery Metadata are used to identify the relevance of the dataset to the particular application. S-104 restricts the multiplicity and contents of **S100_DatasetDiscoveryMetadata** as described in the Remarks column.

Role Name	Name	Description	Mult	Type	Remarks
Class	S100_DatasetDiscoveryMetadata	Metadata about the individual datasets in the Exchange Catalogue	-	-	The optional S-100 attributes <i>updateNumber</i>, <i>updateApplicationDate</i>, <i>otherLocale</i>, and <i>referenceID</i> are not used in S-104 The optional S-100 attributes <i>datasetID</i>, <i>dataCoverage</i>, and <i>editionNumber</i> are mandatory in S-104
Attribute	fileName	Dataset file name	1	URI	See S-100 Part 1, clause 1-4.6
Attribute	description	Short description giving the area or location covered by the dataset	0..1	CharacterString	For example a harbour or port name, between two named locations etc
Attribute	datasetID	Dataset ID expressed as a Maritime Resource Name	1	URN	The URN must be an MRN Made mandatory in S-104 See clause 11.2.3.1
Attribute	compressionFlag	Indicates if the resource is compressed	1	Boolean	<i>true</i> indicates a compressed dataset resource <i>false</i> indicates an uncompressed dataset resource
Attribute	dataProtection	Indicates if the data is encrypted	1	Boolean	<i>true</i> indicates an encrypted dataset resource <i>false</i> indicates an unencrypted dataset resources
Attribute	protectionScheme	Specification of method used for data protection	0..1	S100_ProtectionScheme	In S-100 the only allowed value is "S100p15"
Attribute	digitalSignatureReference	Specifies the algorithm used to compute digitalSignatureValue	1	S100_SE_DigitalSignatureReference (see S-100 Part 15)	
Attribute	digitalSignatureValue	Value derived from the digital signature	1..*	S100_SE_DigitalSignature (see S-100 Part 15)	The value resulting from application of <i>digitalSignatureReference</i> Implemented as the digital signature format specified in Part 15 At least one S100_SE_SignatureOnData is required

Role Name	Name	Description	Mult	Type	Remarks
Attribute	copyright	Indicates if the dataset is copyrighted	1	Boolean	<i>true</i> indicates the resource is copyrighted <i>false</i> Indicates the resource is not copyrighted
Attribute	classification	Indicates the security classification of the dataset	0..1	MD_SecurityConstraints> MD_ClassificationCode (codelist)	1. unclassified 2. restricted 3. confidential 4. secret 5. top secret 6. sensitive but unclassified 7. for official use only 8. protected 9. limited distribution
Attribute	purpose	The purpose for which the dataset has been issued	0..1	S100_Purpose	
Attribute	notForNavigation	Indicates the dataset is not intended to be used for navigation	1	Boolean	<i>true</i> indicates the dataset is not intended to be used for navigation <i>false</i> indicates the dataset is intended to be used for navigation
Attribute	specificUsage	The use for which the dataset is intended	0..1	MD_USAGE>specificUsage (character string)	Information about specific usage(s) for which the dataset is intended
Attribute	editionNumber	The Edition number of the dataset	1	CharacterString	Mandatory in S-104 See clause 8.2
Attribute	issueDate	Date on which the data was made available by the Data Producer	1	Date	
Attribute	issueTime	Time of day at which the data was made available by the Data Producer	0..1	Time	Mandatory when the interval between datasets is shorter than 1 day, such as 6-hourly forecasts
Attribute	boundingBox	The extent of the dataset limits	0..1	EX_GeographicBoundingBox	

Role Name	Name	Description	Mult	Type	Remarks
Attribute	temporalExtent	Specification of the temporal extent of the dataset	0..1	S100_TemporalExtent	<p>The temporal extent is encoded as the date/time of the earliest and latest data records (in coverage datasets) or date/time ranges (in vector datasets)</p> <p>If there is more than one feature in a dataset, the earliest and latest time values of records in all features are used, which means the earliest and latest values may be from different features</p> <p>If date/time information for a feature is not encoded in the dataset, it is treated for the purposes of this attribute as extending indefinitely in the appropriate direction on the time axis, limited by the issue date/time or the cancellation or supersession of the dataset</p> <p>This attribute is encoded if and only if at least one of the start and end of the temporal extent is known</p>
Attribute	productSpecification	The product specification used to create this dataset	1	S100_ProductSpecification	
Attribute	producingAgency	Agency responsible for producing the data	1	CI_ResponsibleParty>CI_Organisation	See S-100 Part 17
Attribute	producerCode	The official IHO Producer Code from S-62	0..1	CharacterString	
Attribute	encodingFormat	The encoding format of the dataset	1	S100_EncodingFormat	Must be HDF5
Attribute	dataCoverage	Area covered by the dataset	1..*	S100_DataCoverage	Mandatory in S-104
Attribute	comment	Any additional information	0..1	CharacterString	
Attribute	defaultLocale	Default language and character set used in the dataset	1	PT_Locale	
Attribute	otherLocale	Other languages and character sets used in the dataset	0..*	PT_Locale	
Attribute	metadataPointOfContact	Point of contact for metadata	0..1	CI_Responsibility > CI_Individual or CI_Responsibility > CI_Organisation	Only if metadataPointOfContact is different from producingAgency
Attribute	metadataDateStamp	Date stamp for metadata	0..1	Date	May or may not be the issue date
Attribute	replacedData	Indicates if a cancelled dataset is replaced by another data file(s)	0..1	Boolean	See Note Mandatory when purpose = cancellation

Role Name	Name	Description	Mult	Type	Remarks
Attribute	dataReplacement	Dataset name	0..*	CharacterString	A dataset may be replaced by 1 or more datasets See Note Mandatory when replacedData = true
Attribute	navigationPurpose	Classification of intended navigation purpose (for Catalogue indexing purposes)	0..3	S100_NavigationPurpose	Mandatory when notForNavigation = false
Role	resourceMaintenance	Information about the frequency of resource updates, and the scope of those updates	0..1	MD_MaintenanceInformation	S-100 restricts the multiplicity to 0..1 and adds specific restrictions on the ISO 19115 structure and content. See clause MD_MaintenanceInformation in S-100 Part 17 Format: PnYnMnDTnHnMnS (XML built-in type for ISO 8601 duration). See S-100 Part 17, clause 17-4.9 for encoding guidance If present, the duration must match the duration encoded in embedded metadata (Table 12-1)

NOTE: *replacedData* and *dataReplacement*. The intended use of the attributes *replacedData* and *dataReplacement* could be, for example, to provide a mechanism for service providers to build automation when providing replacement data sets to customers within existing subscription periods.

12.2.5 S100_NavigationPurpose

Item	Name	Description	Code	Remarks
Enumeration	S100_NavigationPurpose	The Navigational Purpose of the dataset	-	
Value	port	For port and near shore operations	1	
Value	transit	For coast and planning purposes	2	
Value	overview	For ocean crossing and planning purposes	3	

12.2.6 S100_DataCoverage

Role Name	Name	Description	Mult	Type	Remarks
Class	S100_DataCoverage	A spatial extent where data is provided; and the display scale information for the provided data	-	-	The S-100 attributes <i>optimumDisplayScale</i> , <i>minimumDisplayScale</i> , <i>maximumDisplayScale</i> , and <i>temporalExtent</i> are not used.

Attribute	boundingPolygon	A polygon which defines the actual data limit	1	EX_BoundingPolygon	See the Notes below this Table
Attribute	approximateGridResolution	The resolution of gridded or georeferenced data (in metres)	1..*	Real	A single value may be provided when all axes have a common resolution For multiple value provision, use axis order as specified in dataset May be approximate for ungeorectified data For example, for 5 metre resolution, the value 5 must be encoded Mandatory for S-104

NOTE 1: If there are multiple grid features in the dataset, each feature should have a separate *dataCoverage* attribute in dataset discovery metadata, except that the coverages for intersecting or adjacent features with the same grid resolution may be combined at Producer discretion.

NOTE 2: Bounding polygons for grid features should be the same as the spatial extent of the grid.

NOTE 3: A boundingPolygon is restricted to a single GML Polygon with one exterior and 0 or more interiors expressed as Linear Rings using SRS EPSG:4326. The exterior and optional interiors shall be composed of a closed sequence of ≥ 4 coordinate positions expressed individually or as a list (posList). The GML polygon shall have a valid GML identifier.

NOTE 4: For *approximateGridResolution*, if the grid cell size varies over the extent of the grid, an approximated value based on model parameters or production metadata should be used.

12.2.7 S100_Purpose

Item	Name	Description	Code	Remarks
Enumeration	S100_Purpose	The purpose of the dataset	-	See clause 8.2. The S-100 values update and delta are not used
Value	newDataset	Brand new dataset	1	No data has previously been produced for this area
Value	newEdition	New Edition of the dataset or Catalogue	2	Includes new information which has not been previously distributed by updates
Value	cancellation	Dataset or Catalogue that has been cancelled	5	Indicates the dataset or Catalogue should no longer be used and can be deleted

12.2.8 S100_TemporalExtent

Role Name	Name	Description	Mult	Type	Remarks
Class	S100_TemporalExtent	Temporal extent	--		At least one of the <i>timeInstantBegin</i> and <i>timeInstantEnd</i> attributes must be populated; if both are known, both must be populated. The absence of either begin or end indicates indefinite validity in the corresponding direction, limited by the issue date/time or the cancellation or supersession of the dataset
Attribute	timeInstantBegin	The instant at which the temporal extent begins	0..1	DateTime	
Attribute	timeInstantEnd	The instant at which the temporal extent ends	0..1	DateTime	

NOTES:

- (1) In case of overlap in temporal extent between predecessor and successor datasets, the successor dataset prevails. For example, water level or weather forecast datasets may have a temporal extent of N days or hours, but be replaced by new forecast at N – X.
- (2) Precedence and succession can be determined from information in dataset discovery metadata (in particular, issue date, time and temporal extent).

12.2.9 S100_EncodingFormat

Item	Name	Description	Code	Remarks
Enumeration	S100_EncodingFormat	Encoding format	-	Only the HDF5 format is used in S-104
Value	HDF5	The HDF5 data format as defined in Part 10c	3	

12.2.10 S100_ProductSpecification

S-104 uses S100_ProductSpecification without modification.

Role Name	Name	Description	Mult	Type	Remarks
Class	S100_ProductSpecification	The Product Specification contains the information needed to build the specified product	-	-	The optional S-100 attributes <i>name</i>, <i>version</i> and <i>complianceCategory</i> are mandatory in S-104
Attribute	name	The name of the Product Specification used to create the datasets	1	CharacterString	The name in the Product Specification Register, in the IHO Geospatial Information (GI) Registry. For S-104, this is “Water Level Information for Surface Navigation” Mandatory in S-104
Attribute	version	The version number of the Product Specification	1	CharacterString	For example 2.0.0 for S-104 Edition 2.0.0

					Mandatory in S-104
Attribute	date	The version date of the Product Specification	0..1	Date	From the Product Specification Register of the IHO GI Registry. For interim drafts use the version date in Product Specification Metadata
Attribute	productIdentifier	Machine readable unique identifier of a product type	1	CharacterString (Restricted to Product ID values from the IHO Product Specification Register, in the IHO GI Registry)	For S-104 this must be the string "S-104" (without quotes)
Attribute	number	The number used to lookup the product in the Product Specification Register of the IHO GI Registry	1	Integer	From the Product Specification Register in the IHO GI Registry Encode as "0" until this Edition is added to the GI Registry and receives a Registry number. Do not use the number of any other Edition
Attribute	complianceCategory	The level of compliance of the Product Specification to S-100	1	S100_ComplianceCategory	See S-100 Part 4a, clause 4a-5.5 and clause 7.6 in this Product Specification Mandatory in S-104

12.2.11 S100_ComplianceCategory

S-104 uses only Category 4 as defined in S-100 Part 4a, clause 4a-5.5.

Item	Name	Description	Code	Remarks
Enumeration	S100_ComplianceCategory		-	S-104 2.0.0 is compliant with category4
Value	category4	IHO S-100 and IMO harmonized display compliant	4	

12.2.12 S100_ProtectionScheme

S-104 uses S100_ProtectionScheme without modification.

Item	Name	Description	Code	Remarks
Enumeration	S100_ProtectionScheme	Data protection schemes	-	-
Value	S100p15	IHO S-100 Part 15	-	See S-100 Part 15

12.2.13 S100_SupportFileDiscoveryMetadata

The only support files in S-104 are enumeration dictionaries and language packs for Feature Catalogues.

Role Name	Name	Description	Mult.	Type	Remarks
Class	S100_SupportFileDiscoveryMetadata	Metadata about the individual support files in the Exchange Catalogue	-	-	S-104 does not use otherData TypeDescription
Attribute	fileName	Name of the support file	1	URI	See S-100 Part 1, clause 1-4.6 and clause 11.2.5 in this Product Specification
Attribute	revisionStatus	The purpose for which the support file has been issued	1	S100_SupportFileRevisionStatus	For example new, replacement, etc
Attribute	editionNumber	The Edition number of the support file	1	Integer	See clause 8.2.6
Attribute	issueDate	Date on which the data was made available by the Data Producer	0..1	Date	Date on which the support file was made available by its Producer
Attribute	supportFileSpecification	The Specification used to create this file	0..1	S100_SupportFileSpecification	
Attribute	dataType	The format of the support file	1	S100_SupportFileFormat	
Attribute	comment	Optional comment	0..1	CharacterString	
Attribute	compressionFlag	Indicates if the resource is compressed	1	Boolean	<i>true</i> indicates a compressed resource <i>false</i> indicates an uncompressed resource
Attribute	digitalSignatureReference	Specifies the algorithm used to compute digitalSignatureValue	1	S100_SE_DigitalSignatureReference (see S-100 Part 15)	(Type corrected to conform to S-100 Part 15)
Attribute	digitalSignatureValue	Value derived from the digital signature	1..*	S100_SE_DigitalSignature (see S-100 Part 15)	The value resulting from application of digitalSignatureReference Implemented as the digital signature format specified in S-100 Part 15
Attribute	defaultLocale	Default language and character set used in the support file	0..1	PT_Locale	In absence of defaultLocale the language is English in UTF-8 A support file is expected to use only one as locale. Additional support files can be created for other locales

Attribute	supportedResource	Identifier of the resource supported by this support file	0..*	CharacterString	Conventions for identifiers are still to be developed in S-100. S-100 allows file URI, digital signature or cryptographic hash checksums to be used. In the interim, S-104 language packs will reference the Feature Catalogue. For enumeration dictionaries, use the Product Specification identifier and version in URI form
Attribute	resourcePurpose	The purpose of the supporting resource	0..1	S100_ResourcePurpose	Identifies how the supporting resource is used

12.2.14 S100_SupportFileFormat

Item	Name	Description	Code	Remarks
Enumeration	S100_SupportFileFormat	The format used for the support file	-	S-104 uses only XML ; language packs and enumeration dictionaries are all XML files
Value	XML	Extensible Markup Language	4	

12.2.15 S100_SupportFileRevisionStatus

S-104 uses S100_SupportFileRevisionStatus without modification.

Item	Name	Description	Code	Remarks
Enumeration	S100_SupportFileRevisionStatus	The reason for inclusion of the support file in this Exchange Set	-	-
Value	new	A file which is new	1	Signifies a new file
Value	replacement	A file which replaces an existing file	2	Signifies a replacement for a file of the same name
Value	deletion	Deletes an existing file	3	Signifies deletion of a file of that name

12.2.16 S100_SupportFileSpecification

Role Name	Name	Description	Mult	Type	Remarks
Class	S100_SupportFileSpecification	The Standard or Specification to which a support file conforms	-	-	-

Attribute	name	The name of the Specification used to create the support file	1	CharacterString	S-100 for language packs and enumeration dictionary
Attribute	version	The version number of the Specification	0..1	CharacterString	Use the applicable edition of the Standard in the <i>name</i> attribute For example, "5.0.0" for language packs conforming to S-100 Edition 5.0.0
Attribute	date	The version date of the Specification	0..1	Date	Omit or use the publication date in the GI Registry

12.2.17 S100_ResourcePurpose

Item	Name	Description	Code	Remarks
Enumeration	S100_ResourcePurpose	Defines the purpose of the supporting resource	-	S-104 allows only language packs and enumeration dictionaries as support files and the allowed values of the S-100 enumeration are restricted accordingly
Value	languagePack	A Language pack	3	
Value	other	A type of resource not otherwise described	100	For an enumeration dictionary, which supports all datasets for a particular version of the Product Specification

12.2.18 S100_CatalogueDiscoveryMetadata

S-104 uses S100_CatalogueDiscoveryMetadata without modification. This class is used to provide metadata about Feature Catalogues.

Role Name	Name	Description	Mult	Type	Remarks
Class	S100_CatalogueDiscoveryMetadata	Class for S-100 Catalogue metadata	-	-	-
Attribute	fileName	The name for the Catalogue	1	URI	See S-100 Part 1, clause 1-4.6
Attribute	purpose	The purpose for which the Catalogue has been issued	0..1	S100_Purpose (codelist)	The values must be one of the following: 2 new edition 5 cancellation Default is new edition
Attribute	editionNumber	The Edition number of the Catalogue	1	Integer	Initially set to 1 for a given productSpecification.number Increased by 1 for each subsequent New Edition Uniquely identifies the version of the Catalogue
Attribute	scope	Subject domain of the Catalogue	1	S100_CatalogueScope	
Attribute	versionNumber	The version identifier of the Catalogue	1	CharacterString	Human readable version identifier

Attribute	issueDate	The issue date of the Catalogue	1	Date	
Attribute	productSpecification	The Product Specification used to create this file	1	S100_ProductSpecification	
Attribute	digitalSignatureReference	Specifies the algorithm used to compute digitalSignatureValue	1	S100_SE_DigitalSignatureReference (see S-100 Part 15)	
Attribute	digitalSignatureValue	Value derived from the digital signature	1..*	S100_SE_DigitalSignature (see S-100 Part 15)	The value resulting from application of <i>digitalSignatureReference</i> Implemented as the digital signature format specified in S-100 Part 15
Attribute	compressionFlag	Indicates if the resource is compressed	1	Boolean	<i>true</i> indicates a compressed resource <i>false</i> indicates an uncompressed resource
Attribute	defaultLocale	Default language and character set used in the Catalogue	0..1	PT_Locale	In absence of <i>defaultLocale</i> the language is English in UTF-8
Attribute	otherLocale	Other languages and character sets used in the Catalogue	0..*	PT_Locale	

12.2.19 S100_CatalogueScope

Item	Name	Description	Code	Remarks
Enumeration	S100_CatalogueScope	The scope of the Catalogue	-	S-104 Edition 1.1.0 datasets do not contain Interoperability or portrayal Catalogues and the corresponding values are removed
Value	featureCatalogue	S-100 Feature Catalogue	1	

12.2.20 MD_MaintenanceInformation

Role Name	Name	Description	Mult	Type	Remarks
Class	MD_MaintenanceInformation	Information about the scope and frequency of updating	-	-	S-100 restricts the ISO 19115-class to: <ul style="list-style-type: none"> Prohibit <i>maintenanceScope</i>, <i>maintenanceNote</i>, and contact attributes; Define restrictions on <i>maintenanceAndUpdateFrequency</i>, <i>maintenanceDate</i>, and <i>userDefinedMaintenanceFrequency</i> attributes

Attribute	maintenanceAndUpdateFrequency	Frequency with which changes and additions are made to the resource after the initial resource is completed	0..1	MD_MaintenanceFrequencyCode (codelist)	Must be populated if <i>userDefinedMaintenanceFrequency</i> is not present, otherwise optional. See Table MD_MaintenanceFrequencyCode in this Section for values allowed in S-100 metadata
Attribute	maintenanceDate	Date information associated with maintenance of the resource	0..1	CI_Date	Exactly one of <i>maintenanceDate</i> and <i>userDefinedMaintenanceFrequency</i> must be populated Allowed value for <i>dateType</i> : <i>nextUpdate</i>
Attribute	userDefinedMaintenanceFrequency	Maintenance period other than those defined	0..1	TM_PeriodDuration	Exactly one of <i>maintenanceDate</i> and <i>userDefinedMaintenanceFrequency</i> must be populated Only positive durations allowed

12.2.21 MD_MaintenanceFrequencyCode

Item	Name	Description	Code	Remarks
Enumeration	MD_MaintenanceFrequencyCode	Frequency with which modifications and deletions are made to the data after it is first produced	-	S-100 is restricted to only the following values from the ISO 19115-1 codelist. The conditions for the use of a particular value are described in its Remarks
Value	asNeeded	Resource is updated as deemed necessary	1	Use only for datasets which normally use a regular interval for update or supersession, but will have the next update issued at an interval different from the usual Allowed if and only if <i>userDefinedMaintenanceFrequency</i> is not populated
Value	irregular	Resource is updated in intervals that are uneven in duration	2	Use only for datasets which do not use a regular schedule for update or supersession Allowed if and only if <i>userDefinedMaintenanceFrequency</i> is not populated

12.2.22 PT_Locale

Role Name	Name	Description	Mult	Type	Remarks
Class	PT_Locale	Description of a locale	-	-	From ISO 19115-1
Attribute	language	Designation of the locale language	1	LanguageCode	ISO 639-2/T 3-letter language codes
Attribute	country	Designation of the specific country of the locale language	0..1	CountryCode	ISO 3166-2 2-letter country codes

Attribute	characterEncoding	Designation of the character set to be used to encode the textual value of the locale	1	MD_CharacterSetCode	UTF-8 is used in S-100
-----------	-------------------	---	---	---------------------	------------------------

LanguageCode, *CountryCode* and *MD_CharacterSetCode* are codelists which are defined in resource files within the S-100 XML schemas package and described in the documentation for the S-100 XML Schemas.

12.2.23 S100_SE_CertificateContainer

S-104 uses S100_SE_CertificateContainer without modification.

Role Name	Name	Description	Mult	Type	Remarks
Class	S100_SE_CertificateContainer	A set of signed public key certificates	-	-	Used in S-100 Part 17 Exchange Catalogues
Attribute	schemeAdministrator	The Scheme Administrator identity	0..1	CharacterString	The identity of the Scheme Administrator is contained in the "id" attribute of the <i>schemeAdministrator</i> element. The Scheme Administrator certificate is NOT included in catalogue metadata as it is independently verified by the implementing system
Attribute	certificate	A signed public key certificate	1..*	Base 64 encoded Character String	Conforms to X.509 encoding. Contains a digitally signed identifier of an entity

12.2.24 S100_SE_DigitalSignatureReference

S-104 uses only the *ECDSA-384-SHA2* value of S100_SE_DigitalSignatureReference, in conformity with the restriction in S-100 Part 15, clauses 15-8.7 and 15-8.11.7.

Item	Name	Description	Code	Remarks
Enumeration	S100_SE_DigitalSignatureReference	Algorithm used to compute the digital signature	-	Only ECDSA is currently used in implementations of S-100 for file based transfer of data to ECDIS. Other values are included for interoperability with other implementations by external standards. See S-100 Part 15, clause 15-8.4
Value	ECDSA-384-SHA2		8	384 bits ECDSA: SHA2-384

12.2.25 S100_SE_DigitalSignature

S-104 conforms to S-100 Part 15, clause 15-8-11.4, which states: "The class S100_SE_DigitalSignature is realized as one of either S100_SE_SignatureOnData (a digital signature of a particular identified resource) or an additional digital signature defined using the [same class] which is either a S100_SE_SignatureOnData or S100_SE_SignatureOnSignature element as described in clause 15-8.8. S-100 Part 17 metadata thus allows for multiple digital signatures, a single mandatory S100_SE_SignatureOnData and any number of additional signatures, either of the data or other signatures." (In S-100, this class is not documented separately.)

S-104 uses the class S100_SE_DigitalSignature without modification; however, in S-100 exchange catalogues it is implemented by one of its subclasses S100_SE_SignatureOnData or S100_SE_SignatureOnSignature.

Role Name	Name	Description	Mult	Type	Remarks
Class	S100_SE_DigitalSignature		-	Base64 encoded digital signature value	See S-100 Part 15, clause 15-8 Abstract class substituted by one of its subclasses.
Attribute	id	Identifier of the digital signature	1	CharacterString	Every signature entry has a unique identifier
Attribute	certificateRef	Signed Public Key	1	CharacterString	Identifier of the certificate against which the digital signature validates

12.2.26 S100_SE_SignatureOnData

S-104 uses S100_SE_SignatureOnData without modification.

Role Name	Name	Description	Mult	Type	Remarks
Class	S100_SE_SignatureOnData		-	Base64 encoded digital signature value	See S-100 Part 15, clause 15-8 Subclass of S100_SE_DigitalSignature
Attribute	id	Identifier of the digital signature	1	CharacterString	Every signature entry has a unique identifier (Inherited attribute)
Attribute	certificateRef	Signed Public Key	1	CharacterString	Identifier of the certificate against which the digital signature validates (Inherited attribute)
Attribute	dataStatus	The digital signature	1	DataStatus	

12.2.27 S100_SE_SignatureOnSignature

S-104 uses S100_SE_SignatureOnSignature without modification.

Role Name	Name	Description	Mult	Type	Remarks
Class	S100_SE_SignatureOnSignature		-	Base64 encoded digital signature value	See S-100 Part 15, clause 15-8 Subclass of S100_SE_DigitalSignature
Attribute	id	Identifier of the digital signature	1	CharacterString	Every signature entry has a unique identifier (Inherited attribute)

Attribute	certificateRef	Signed Public Key	1	CharacterString	Identifier of the certificate against which the digital signature validates (Inherited attribute)
Attribute	signatureRef	The digital signature referenced	1		

12.2.28 DataStatus

S-104 uses the S-100 enumeration DataStatus defined in S-100 Part 15 without modification.

Item	Name	Description	Code	Remarks
Enumeration	DataStatus	The state of data when a digital signature is created	-	
Value	unencrypted	The data is unencrypted and uncompressed	-	For example, supporting resources
Value	encrypted	The data is compressed and encrypted	-	For example, copy protected datasets
Value	compressed.	The data is compressed only	-	For example, archives of multiple resources

12.2.29 EX_GeographicBoundingBox

From ISO 19115-1.

Role Name	Name	Description	Mult	Type	Remarks
Class	EX_GeographicBoundingBox	Geographic position of the dataset	-	-	Defined in ISO 19115-1: Geographic position of the resource
Attribute	westBoundLongitude	Western-most coordinate of the limit of the dataset extent, expressed in longitude in decimal degrees (positive east)	1	Real	Arc degrees
Attribute	eastBoundLongitude	Eastern-most coordinate of the limit of the dataset extent, expressed in longitude in decimal degrees (positive east)	1	Real	Arc degrees
Attribute	southBoundLatitude	Southern-most coordinate of the limit of the dataset extent, expressed in latitude in decimal degrees (positive north)	1	Real	Arc degrees
Attribute	northBoundLatitude	Northern-most, coordinate of the limit of the dataset extent expressed in latitude in decimal degrees (positive north)	1	Real	Arc degrees

NOTE (from ISO 19115-1): This is only an approximate reference so specifying the Coordinate Reference System is unnecessary and need only be provided with a precision of up to two decimal places.

12.2.30 EX_BoundingPolygon

From ISO 19115-1.

Role Name	Name	Description	Mult	Type	Remarks
Class	EX_BoundingPolygon	Boundary enclosing the dataset, expressed as the closed set of (x,y) coordinates of the polygon (last point replicates first point)	-	-	Defined in ISO 19115-1: enclosing geometric object which locates the resource, expressed as a set of (x,y) coordinate(s)
Attribute	polygon	Sets of points defining the bounding polygon	1	GM_Object	Must be a GML polygon with one exterior and 0 or more interiors expressed as Linear Rings using SRS EPSG:4326 (See S-100 Part 17)

NOTE (from ISO 19115-1): If a polygon is used it should be closed (last point replicates first point).

Page intentionally left blank

12.3 Carrier Metadata

Kommenterad [rmm29]: Remove all formats other than RG

The metadata for the S-104 product is divided in three sections, corresponding to the General Metadata (Table 12-1), the Feature Type Metadata (Table 12-2), and the Feature Instance Metadata (Table 12-3 and Table 12-4). The Instance Metadata is subdivided into metadata attached to the instance as a whole (Table 12-3) and metadata attached to individual values groups (Table 12-4). Since these values do not reside in the Metadata blocks in the Exchange Catalogue, but are in the HDF5 files, they are referred to as Carrier Metadata. The Carrier Metadata consists of the data and parameters needed to read and interpret the information in the Water Level product even if the other S-104 Metadata files are unavailable.

Note that in Tables 12-1 – 12-4, some of the metadata variables have restrictions on their core values (that is, whether they are optional or mandatory, the specific values allowed, etc) that are not imposed in S-100. These are grouped under the heading '*Additional restrictions on core metadata for S-104*'.

Mandatory attributes in a section of a Table that is designated for one or more specified *dataCodingFormat* values are mandatory only for the specified *dataCodingFormat* value(s).

It is suggested for any enumeration in S-104, to use unsigned integer types (preferably standard integer type H5T_STD_U8LE) for the base type of the numeric code when creating the enumeration⁴.

Figures 12-5 through 12-9 depict the carrier metadata at each level of the structural hierarchy in an HDF5 dataset. The elements (groups and metadata) defined in S-100 are distinguished from those defined in S-104 by prefix and shade. Figure 12-5 is a summary diagram depicting all levels of the structural and their associated metadata components for all the coverage types used in S-104. Figures 12-6 – 12-9 show the details for each structural level and each coverage type.

The same information as in Figures 12-6 through 12-9 is depicted in Annex B (Figures B-6 – B-7) but organised by coverage instead of levels in the HDF5 structural hierarchy.

The maximum length of all string HDF5 attributes is 300 characters.

⁴ See the guidance on HDF5 datatypes (<https://support.hdfgroup.org/HDF5/Tutor/datatypes.html>, retrieved 20 August 2021) for more information on the use of standard vs native types when creating a dataset and for memory operations (read/write).

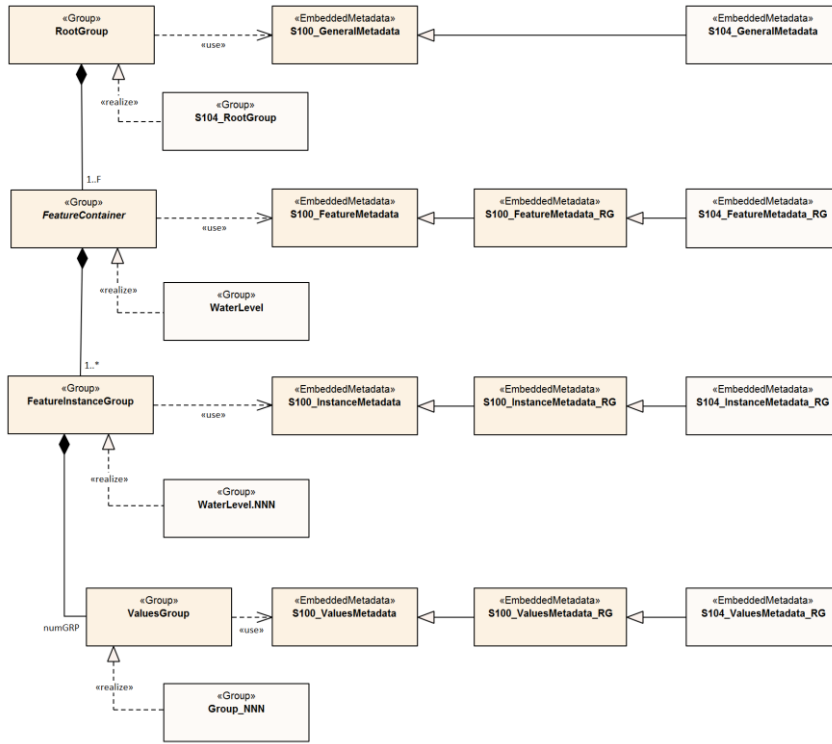

Figure 12-5 – Carrier metadata for the S-104 HDF5 group hierarchy

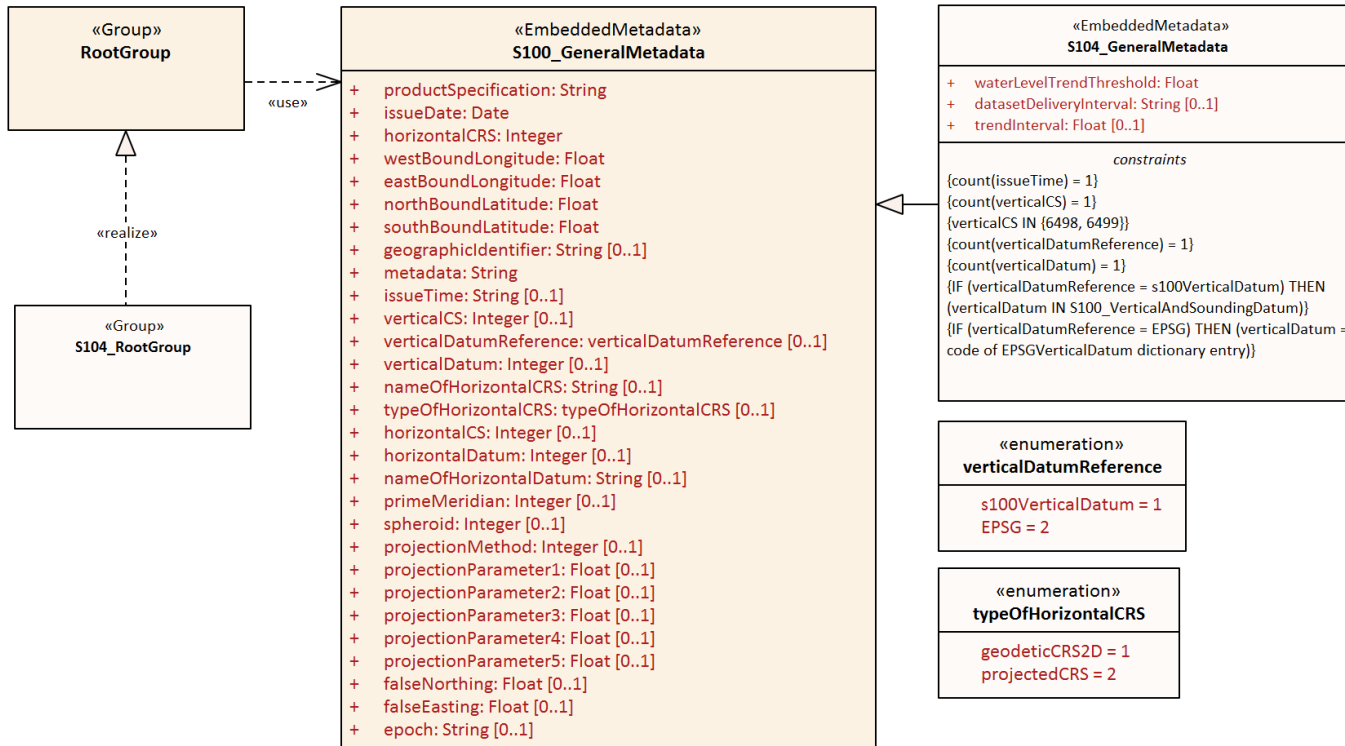

Figure 12-6 – General metadata – Carrier metadata for the root group

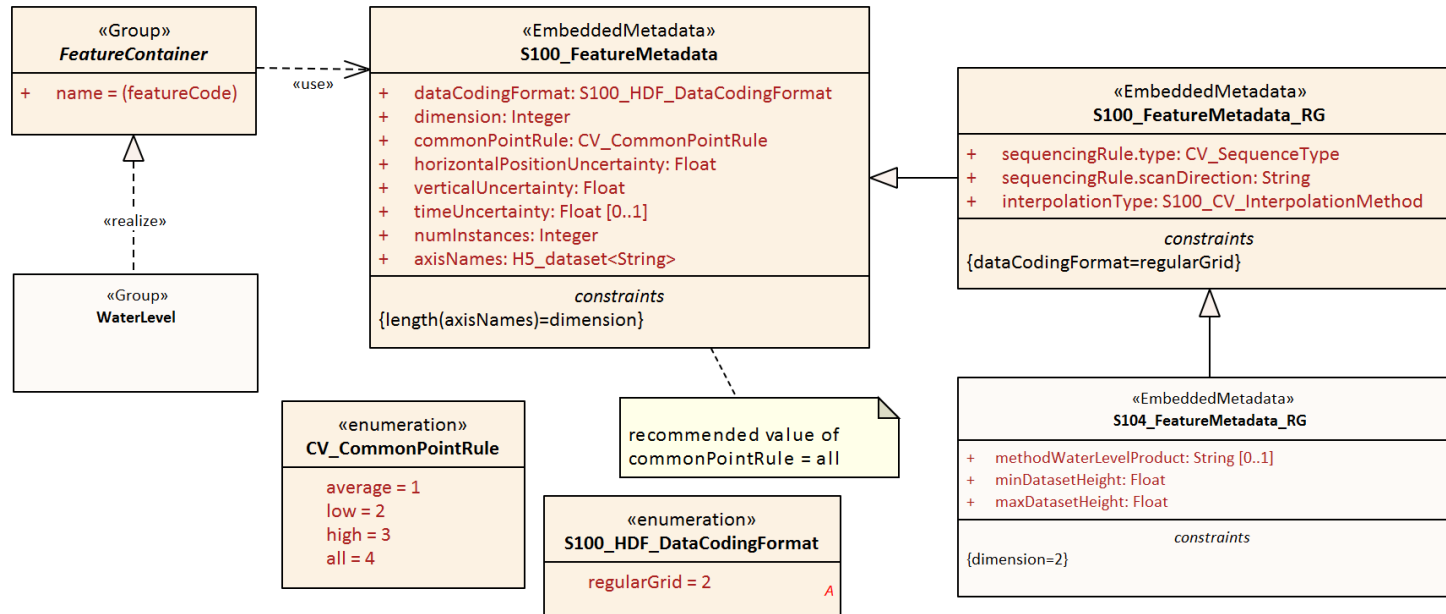

Figure 12-7 – Feature Type metadata – Carrier metadata for the Feature Container group

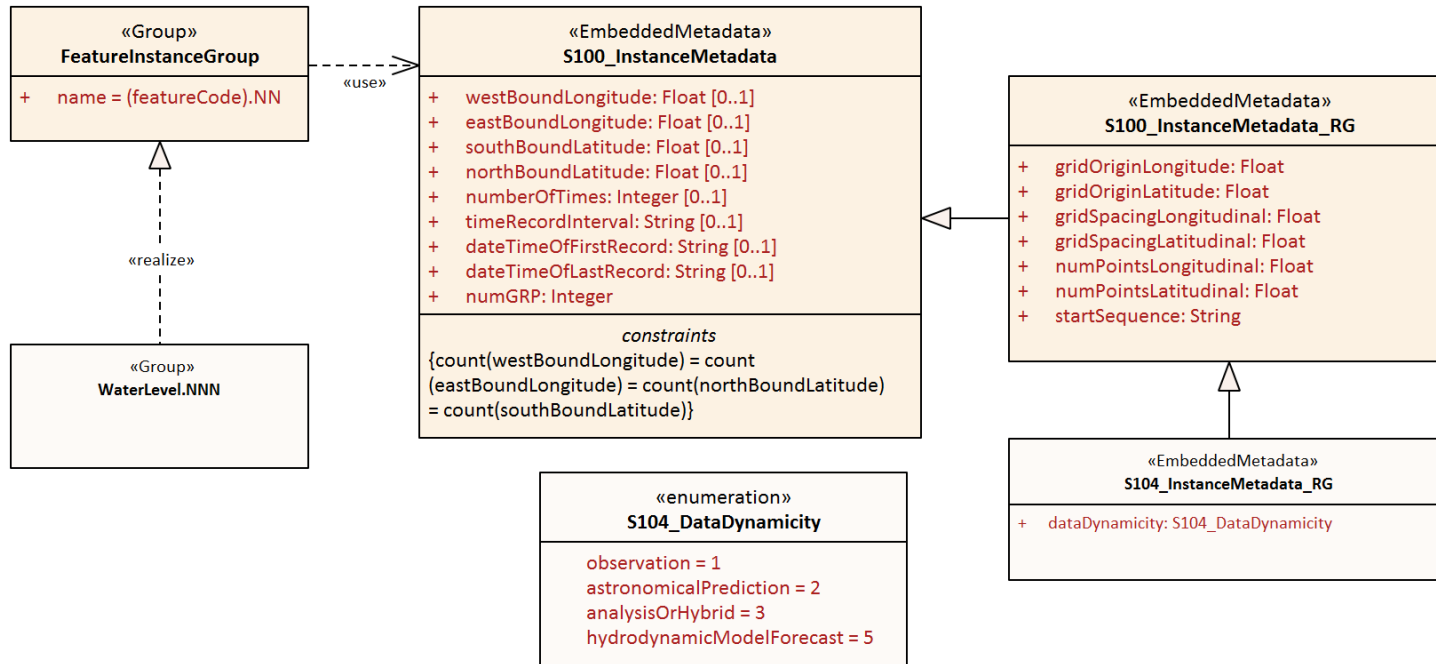

Figure 12-8 – Feature Instance metadata – Carrier metadata for the Feature Instance group

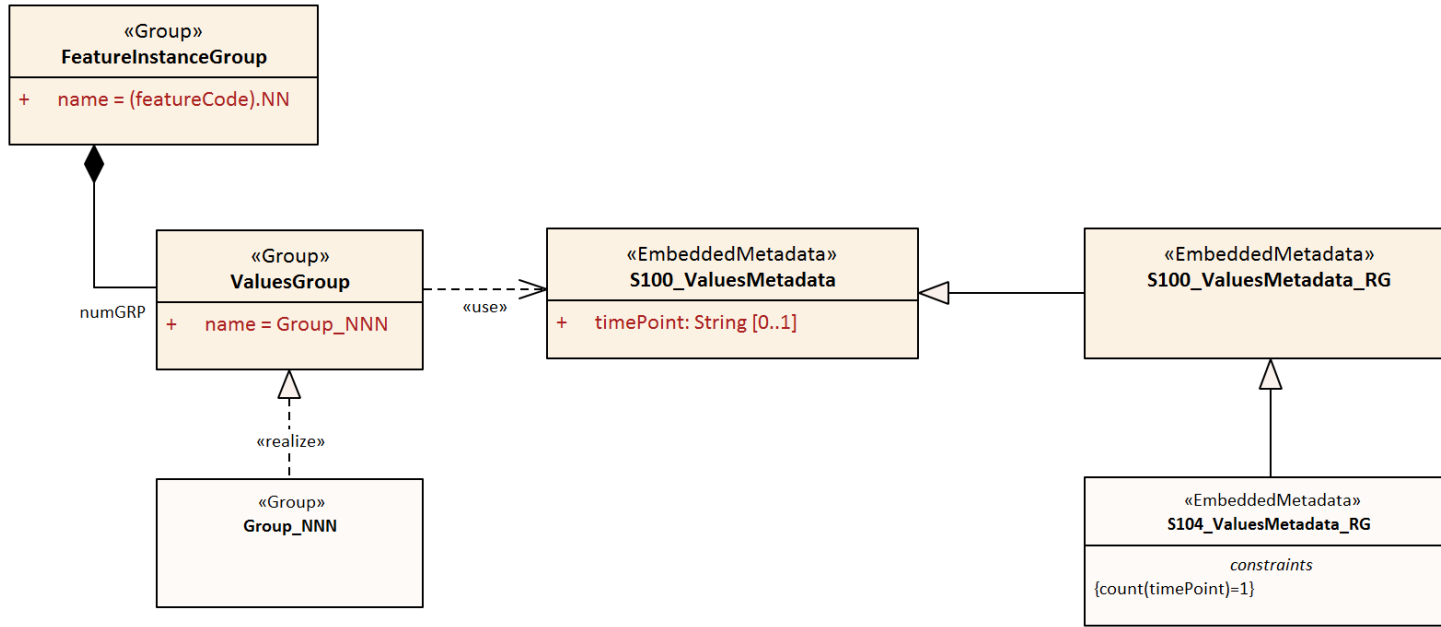

Figure 12-9 – Feature Instance metadata – Carrier metadata for the Values group in each Feature Instance group

For all carrier metadata, latitude and longitude values are precise to 10^{-7} degrees except where noted. All times are in UTC format.

All enumeration attributes in carrier metadata must be implemented as HDF5 enumerations. The base type for all enumeration attributes in the following tables must be 8-bit unsigned integer in the HDF5 standard integer type H5T_STD_U8LE.

Integer types are signed integers unless designated as "unsigned".

Strings must use UTF-8 character encoding. String padding is not specified in this edition of the Product Specification due to the diversity of API framework treatment of padding.

12.3.1 General metadata - details

Table 12-1 – General metadata, related to the entire HDF5 file (see S-100 Part 10c, Table 10c-6). All times are in UTC format

No	Name	Camel Case	Mult	Data Type	Remarks and/or Units
1	Product Specification number and version	productSpecification	1	String	This must be encoded as 'INT.IHO.S-104.X.Y', with X representing the Edition number and Y the revision number. See Note 6
2	Date of data product issue	issueDate	1	String	Date must be consistent with issueDate in discovery metadata
3	Horizontal Coordinate Reference System	horizontalCRS	1	Integer 32-bit	EPSG code (cf. clause 5.1) or -1 if user defined EXAMPLE 1: 4326 (for WGS84) See https://spatialreference.org/ref/epsg/?page=1 EXAMPLE 2: EPSG:9057 is WGS 84 (G1762) realization with valid epoch 2005.0
4	Bounding box	westBoundLongitude	1	Float 32-bit	Area encompassing all feature instances Units are Decimal Degrees in the EPSG 4326 CS. In accordance with ISO 19115-1 these coordinates need be accurate only to two decimal places
5		eastBoundLongitude	1	Float 32-bit	
6		southBoundLatitude	1	Float 32-bit	
7		northBoundLatitude	1	Float 32-bit	
8	Geographic location of the resource (by description)	geographicIdentifier	0..1	String	Description, or location code from list agreed by data producers (In S-100: EX_Extent > EX_GeographicDescription.geographicIdentifier > MD_Identifier.code)
9	Metadata file name ⁵	metadata	1	String	Name of XML metadata file for the HDF5 file Form: MD_<hdf file name>.XML. The empty string means this file is not provided
10	Name of the horizontal CRS	nameOfHorizontalCRS	0..1	String	Mandatory if horizontalCRS = -1

⁵ As of February 2024 it is possible that the final version of S-100 5.2.0 might make this attribute optional, in which case it should be removed from S-104 2.0.0.

No	Name	Camel Case	Mult	Data Type	Remarks and/or Units
11	Type of the horizontal CRS	typeOfHorizontalCRS	0..1	Enumeration	Mandatory if horizontalCRS = -1 See Table 12-5
12	Horizontal coordinate system	horizontalCS	0..1	Integer 32-bit	Mandatory if horizontalCRS = -1 Allowed values if typeOfHorizontalCRS = 1 (Geodetic CRS 2D): 6422 (Lat, Lon – degree) Allowed values if typeOfHorizontalCRS = 2 (Projected CRS): 4400 (Easting, Northing – metres) 4500 (Northing, Easting – metres)
13	Horizontal datum	horizontalDatum	0..1	Integer 32-bit	Mandatory if horizontalCRS = -1 EPSG code or -1 if user defined
14	Name of horizontal datum	nameOfHorizontalDatum	0..1	String	Mandatory if horizontalDatum = -1
15	Prime meridian	primeMeridian	0..1	Integer 32-bit	Mandatory if horizontalDatum = -1; EPSG Code
16	Spheroid	spheroid	0..1	Integer 32-bit	Mandatory if horizontalDatum = -1; EPSG Code
17	Projection method	projectionMethod	0..1	Integer 32-bit	Mandatory if typeOfHorizontalCRS = 2; EPSG Code, see Table 12-7
18	Projection parameter 1	projectionParameter1	0..1	Float 64-bit	Only if projectionMethod is used. See Table 12-7
19	Projection parameter 2	projectionParameter2	0..1	Float 64-bit	Only if projectionMethod is used. See Table 12-7
20	Projection parameter 3	projectionParameter3	0..1	Float 64-bit	Only if projectionMethod is used. See Table 12-7
21	Projection parameter 4	projectionParameter4	0..1	Float 64-bit	Only if projectionMethod is used. See Table 12-7
22	Projection parameter 5	projectionParameter5	0..1	Float 64-bit	Only if projectionMethod is used. See Table 12-7
23	False northing	falseNorthing	0..1	Float 64-bit	Only if projectionMethod is used. To be applied to the coordinates at axis Northing. [m]
24	False easting	falseEasting	0..1	Float 64-bit	Only if projectionMethod is used. To be applied to the coordinates at axis Easting. [m]
25	Epoch of realization	epoch	0..1	String	Code denoting the epoch of the geodetic datum used by the CRS. For example, 2005.0 for the G1762 realization of the geodetic datum for WGS84. Must match epoch denoted by horizontalCRS.
<i>Additional metadata for S-104</i>					

No	Name	Camel Case	Mult	Data Type	Remarks and/or Units
26	Water level trend threshold	waterLevelTrendThreshold	1	Float 32-bit	Critical value used to determine steady water level trend. Units are metres/hour (m/hr). For example, 0.2. See Annex A (DCEG)
27	Dataset delivery interval	datasetDeliveryInterval	0..1	String	The expected time interval between availability of successive datasets for time-varying data. Must be formatted as PnYnMnDTnHnMnS (ISO 8601 duration). See Note 8
28	Trend Interval	trendInterval	0..1	Integer 32-bit unsigned	The interval over which trend at a particular time is calculated Unit: minutes
<i>Additional restrictions on core general metadata for S-104</i>					
29	Time of data product issue	issueTime	1	String	Mandatory for S-104. S-100 Time format. All times are in UTC. For example 123000Z
30	Vertical coordinate system	verticalCS	1	Integer 32-bit	Mandatory for S-104 EPSG Code; Allowed Values • 6498 (Depth– Metres– Orientation Down) • 6499 (Height– Metres– Orientation Up)
31	Vertical coordinate base	verticalCoordinateBase	1	Enumeration	Mandatory in S-104 The only allowed value is verticalDatum (see S-100 Table 10c-22)
31	Vertical datum reference	verticalDatumReference	1	Enumeration	Mandatory beginning S-104 Edition 1.1 1: S-100 vertical datum 2: EPSG
32	Vertical datum	verticalDatum	1	Integer 32-bit	Mandatory beginning S-104 Edition 1.1 If verticalDatumReference = 1 this is one of the standard values from S100_VerticalAndSoundingDatum If verticalDatumReference = 2 this is an EPSG code for vertical datum

NOTE 1: If the CRS is user defined only the following coordinate systems are supported:

- a. Geodetic CS (Latitude, Longitude) – Degrees; and
- b. Cartesian CS (Northing, Easting or Easting, Northing) – Metres.

NOTE 2: For the horizontal Datum all EPSG predefined Datums are allowed or any combination of predefined Prime Meridians or predefined Spheroids.

NOTE 3: The projection methods are limited to those given in **Table 12-7**.

NOTE 4: If the horizontal CRS is defined by the EPSG code, the defined CRS should not use any other elements than the one allowed for user defined CRSs; (for example, no projection method that is not in the Table).

NOTE 5: The bounding box is the data set bounding box; the coverage data feature instances may or may not cover the entire bounding box. If there is only a single coverage feature, its extent may or may not be the same as the data set.

NOTE 6: Beginning S-100 Edition 5.0.0, class **S100_ProductSpecification** (S-100 Part 17) contains a *productIdentifier* field whose value must be the Product ID value from the IHO Product Specification Register in the IHO Geospatial Information Registry. Attribute *productSpecification* in **Table 12-1** must use exactly the same value.

NOTE 7: S-104 does not use *seaSurface* and *seaFloor* datums, which makes attribute *verticalCoordinateBase* redundant. It is included in order to ensure compliance with generic validation checks for attribute *verticalDatum*.

NOTE 8: Dataset delivery interval is encoded only if the dataset is part of a sequence delivered at known intervals (for example, daily, weekly, or 6-hourly forecasts). S-100 Part 17, clause 17-4.9 contains detailed guidance for encoding the discovery metadata equivalent of this attribute (*userDefinedMaintenanceFrequency*) and the same guidelines apply to encoding this attribute. If this attribute and its discovery metadata equivalent are both encoded (in the HDF5 dataset and discovery metadata block respectively), the durations encoded by them must be the same. Intervals greater than monthly may be encoded at Producer discretion.

12.3.2 Feature Type metadata - details

Table 12-2 – Feature Type metadata, pertaining to the WaterLevel feature type (see S-100 Part 10c, Table 10c-10)

No	Name	Camel Case	Mult	Data Type	Remarks and/or Units
1	Data organization index (Used to read the data. See Table 10-1)	dataCodingFormat	1	Enumeration	See Table 12-9 . The allowed values are: 2: Regularly-gridded arrays This Product Specification allows the use of only value 2 from S-100
2	Dimension	dimension	1	Integer, 8-bit unsigned	The (spatial) dimension of the feature instances. For water levels, use 2 This is the number of coordinate axes, not the rank of the HDF5 arrays storing coordinates or values
3	Common Point Rule	commonPointRule	1	Enumeration	The procedure used ⁶ for evaluating the coverage at a position that falls on the boundary or in an area of overlap between geometric objects 1: average 2: low 3: high 4: all (recommended)
4	Horizontal position uncertainty	horizontalPositionUncertainty	1	Float 32-bit	-1.0 (unknown) or positive value (m)
5	Vertical position uncertainty	verticalUncertainty	1	Float 32-bit	-1.0 (unknown) or positive value (m)
6	Time uncertainty	timeUncertainty	0..1	Float 32-bit	-1.0 (unknown) or positive value (s)

Kommenterad [rmm30]: Remove metadata for non-RG formats

⁶ The "procedure" referred to means only *evaluate* operations as defined in ISO 19123 ("accept a DirectPosition as input and return a set of Records of feature attribute values for that direct position"). Applications must apply their own evaluation methods to the resulting list, for example, "water level adjustment" in ECDIS (S-98 Annex C) should select the water level value that produces the shallowest depth at the position.

No	Name	Camel Case	Mult	Data Type	Remarks and/or Units
7	Number of feature instances	numInstances	1	Integer 32-bit unsigned	
<i>Additional metadata for S-104</i>					
8	Methodology	methodWaterLevelProduct	0..1	String	Brief description of tide gauge type, forecast method or model, etc
9	Minimum water level height in dataset	minDatasetHeight	1	Float 32-bit	Height in verticalCS in Table 12-1 Use the same precision as the corresponding attribute in the values record
10	Maximum water level height in dataset	maxDatasetHeight	1	Float 32-bit	Height in verticalCS in Table 12-1 Use the same precision as the corresponding attribute in the values record
dataCodingFormat = 2 (regular Grid)					
11	Sequencing Rule	sequencingRule.type	1	Enumeration	Method to be used to assign values from the sequence of values to the grid coordinates. Components: type: Enumeration CV_SequenceType Must be 1 (for 'linear')
12		sequencingRule.scanDirection	1	String	scanDirection: String <axisNames entry> (comma-separated). For example "latitude,longitude"
13	Interpolation Type	interpolationType	1	Enumeration	Interpolation method recommended for evaluation of the S100_GridCoverage Values: S100_CV_InterpolationMethod (S-100 Part 8). Recommended value: nearestneighbor

12.3.3 Feature Instance metadata - details

Table 12-3 – Feature Instance metadata, pertaining to the feature instance (see S-100 Part 10c, Table 10c-12). All times are in UTC format

No	Name	Camel Case	Mult	Data Type	Remarks and/or Units
1	Bounding box	westBoundLongitude	0..1	Float 32-bit	Area of grid, set of stations, etc Units are decimal degrees These are used if the feature instance has a bounding box different from the bounding box of the whole dataset. This may happen, for example, if there is more than one feature instance in the dataset
2		eastBoundLongitude	0..1	Float 32-bit	
3		southBoundLatitude	0..1	Float 32-bit	
4		northBoundLatitude	0..1	Float 32-bit	
5	Number of time records	numberOfTimes	1	Integer 32-bit unsigned	The total number of time records. Mandatory in S-104. For water level adjustment to be non-trivial, there should be multiple time records (an acceptable minimum is undetermined at this time).

Kommentarad [rmm31]: Remove metadata for non-RG formats

No	Name	Camel Case	Mult	Data Type	Remarks and/or Units
6	Time interval	timeRecordInterval	0..1	Integer 16-bit unsigned	The interval between time records. Units: Seconds. Recommended if the interval between successive values is uniform.
7	Valid time of earliest value	dateTimeOfFirstRecord	1	String	DateTime format. First record in the Instance. All times are in UTC Mandatory in S-104
8	Valid time of latest value	dateTimeOfLastRecord	1	String	DateTime format Mandatory in S-104.
9	Number of values groups	numGRP	1	Integer 32-bit unsigned	Number of Values Groups. For dataCodingFormat = 2 equals the number of time points given by numberOfTimes
<i>Additional metadata for S-104</i>					
10	Data dynamicity	dataDynamicity	1	Enumeration	See Table 12-10. The allowed values are: 1: Observation 2: Astronomical prediction 3: Analysis or hybrid method 5: Hydrodynamic model forecast
dataCodingFormat = 2 (regular Grid)					
11	Longitude of grid origin	gridOriginLongitude	1	Float-Double (64-bit)	Degrees
12	Latitude of grid origin	gridOriginLatitude	1	Float-Double (64-bit)	Degrees
13	Grid spacing, longitudinal	gridSpacingLongitudinal	1	Float-Double (64-bit)	Degrees
14	Grid spacing, latitudinal	gridSpacingLatitudinal	1	Float-Double (64-bit)	Degrees
15	Number of points, longitudinal	numPointsLongitudinal	1	Integer 32-bit unsigned	numCOLS
16	Number of points, latitudinal	numPointsLatitudinal	1	Integer 32-bit unsigned	numROWS
17	Start sequence	startSequence	1	String	For example, "0,0" (without quotes) for scans starting at lower left corner i=0, j=0. For upper left, "0,n", where n is the value of numROWS-1. First character represents first axis in sequencingRule.scanDirection. (Table 12-2), which here is latitude

12.3.4 Values Group attributes - details

An expanded new metadata block is required for the Values Groups (Table 12-4). The variables *stationName* and *stationIdentification* have been added for both identification and possibly for inclusion in the text of the graph. The series start and end times, number of records, and time interval index are included since they may differ for each series.

Kommenterad [rmm32]: Remove metadata for non-RG formats

Table 12-4 – Values Group attributes (see S-100 Part 10c, Table 10c-19). All times are in UTC format

No	Name	Camel Case	Mult	Data Type	Remarks and/or Units
1	Time stamp	timePoint	1	String	DateTime. All times are in UTC. See Clause 10.2.2.5
2	Water level trend threshold	waterLevelTrendThreshold	0..1	Float 32-bit	Critical value used to determine steady water level trend. Units are metres/hour (m/hr). For example, 0.2. See Annex A (DCEG)
3	Trend Interval	trendInterval	0..1	Integer 32-bit unsigned	The interval over which trend at a particular time is calculated Unit: minutes. Default: 60 minutes

12.3.5 Additional enumerations used in carrier metadata**Table 12-5 – Type of the horizontal CRS**

Item	Name	Description	Code	Remarks
Enumeration	typeOfHorizontalCRS	Codes for describing the type of the two-dimensional horizontal CRS	-	
Literal	geodeticCRS2D	Two-dimensional geodetic CRS	1	
Literal	projectedCRS	Projected CRS	2	

Table 12-6 – Vertical datum reference

Item	Name	Description	Code	Remarks
Enumeration	verticalDatumReference		-	
Literal	s100VerticalDatum	The vertical datum is one of those listed in S100_VerticalAndSoundingDatum	1	
Literal	EPSG	The vertical datum is one of those listed in the EPSG Registry	2	

Table 12-7 – Projection methods and their parameters

Name	EPSG Code	Parameter 1	Parameter 2	Parameter 3	Parameter 4	Parameter 5
Mercator	9805	Latitude of 1st standard parallel	Longitude of natural origin	-	-	-
Transverse Mercator	9807	Latitude of natural origin	Longitude of natural origin	Scale factor at natural origin	-	-
Oblique Mercator	9815	Latitude of projection centre	Longitude of projection centre	Azimuth of initial line	Angle from Rectified to Skew Grid	Scale factor on initial line
Hotline Oblique Mercator	9812	Latitude of projection centre	Longitude of projection centre	Azimuth of initial line	Angle from Rectified to Skew Grid	Scale factor on initial line
Lambert Conic Conformal (1SP)	9801	Latitude of natural origin	Longitude of natural origin	Scale factor at natural origin	-	-
Lambert Conic Conformal (2SP)	9802	Latitude of false origin	Longitude of false origin	Latitude of 1st standard parallel	Latitude of 2nd standard parallel	-
Oblique Stereographic	9809	Latitude of natural origin	Longitude of natural origin	Scale factor at natural origin	-	-

Polar Stereographic	9810	Latitude of natural origin	Longitude of natural origin	Scale factor at natural origin	-	-
Krovak Oblique Conic Conformal	9819	Latitude of projection centre	Longitude of projection centre	Azimuth of initial line	Latitude of pseudo standard parallel	Scale factor on pseudo standard parallel
American Polyconic	9818	Latitude of natural origin	Longitude of natural origin	-	-	-
Albers Equal Area	9822	Latitude of false origin	Longitude of false origin	Latitude of 1st standard parallel ⁵	Latitude of 2nd standard parallel ⁶	-
Lambert Azimuthal Equal Area	9820	Latitude of natural origin	Longitude of natural origin	-	-	-

Table 12-8 – S100_VerticalAndSoundingDatum

Item	Name	Description	Code	Remarks
S100_Codelist	S100_VerticalAndSoundingDatum	Allowable vertical and sounding datums	-	S-104 allows only the standard values of this codelist, which makes it effectively an enumeration for S-104 purposes
Value	meanLowWaterSprings		1	(MLWS)
Value	meanLowerLowWaterSprings		2	-
Value	meanSeaLevel		3	(MSL)
Value	lowestLowWater		4	-
Value	meanLowWater		5	(MLW)
Value	lowestLowWaterSprings		6	-
Value	approximateMeanLowWaterSprings		7	-
Value	indianSpringLowWater		8	-
Value	lowWaterSprings		9	-
Value	approximateLowestAstronomicalTide		10	-
Value	nearlyLowestLowWater		11	-
Value	meanLowerLowWater		12	(MLLW)
Value	lowWater		13	(LW)
Value	approximateMeanLowWater		14	-
Value	approximateMeanLowerLowWater		15	-
Value	meanHighWater		16	(MHW)
Value	meanHighWaterSprings		17	(MHWS)
Value	highWater		18	(HW)
Value	approximateMeanSeaLevel		19	-
Value	highWaterSprings		20	-
Value	meanHigherHighWater		21	(MHHW)
Value	equinoctialSpringLowWater		22	-

Item	Name	Description	Code	Remarks
Value	lowestAstronomicalTide		23	(LAT)
Value	localDatum		24	-
Value	internationalGreatLakesDatum 1985		25	-
Value	meanWaterLevel		26	-
Value	lowerLowWaterLargeTide		27	-
Value	higherHighWaterLargeTide		28	-
Value	nearlyHighestHighWater		29	-
Value	highestAstronomicalTide		30	(HAT)
Value	balticSeaChartDatum2000	Baltic Sea Chart Datum 2000	44	-
Value	internationalGreatLakesDatum 2020	The 2020 update to the International Great Lakes Datum, the official reference system used to measure water level heights in the Great Lakes, connecting channels, and the St Lawrence River system	46	Unlike the previous two IGLDs, this datum update will use a geoid-based vertical datum that will be accessible using global navigation satellite systems (GNSS) such as the Global Positioning System (GPS)

Table 12-9 – S100_HDF_DataCodingFormat

Item	Name	Description	Code	Remarks
Enumeration	S100_HDF_ DataCodingFormat	Data coding formats for S-100 HDF5 data	-	S-104 does not use movingPlatform, irregularGrid, or variableCellSize data coding formats
Value	regularGrid	Data at grid points forming a regular grid with constant cell spacing	2	Regular grids are commonly composed of perpendicularly crossing lines of equal spacing on each dimension, creating square or rectangular cells

Kommenterad [rmm33]: Remove all except regularGrid

Table 12-10 – S104_DataDynamicity

Item	Name	Description	Code	Remarks
Enumeration	S104_DataDynamicity	Classification of data according to the relationship between the time of its collection, generation, or calculation of generation parameters, in relation to the time of publication of the dataset	-	
Value	observation	Values from in-situ sensor(s); may be quality controlled and stored after collection	1	Only real-time observations See also Notes 1 and 2 below
Value	astronomicalPrediction	Values computed using harmonic analysis or other proven method of tidal analysis	2	IHO Resolution 3/1919, as amended

Kommenterad [rmm34]: Reduce to WLA-only types

Value	analysisOrHybrid	Values calculated by statistical or other indirect methods, or a combination of methods	3	A hybrid method combines two or more approaches
Value	hydrodynamicForecast	Values calculated from a two- or three-dimensional dynamic simulation of future conditions using predicted data for boundary forcing, via statistical method or combination	5	A forecast is a simulation made for many hours into the future using predicted winds, water levels, etc

NOTE 1: The time period covered by the observations should be encoded in the metadata attribute *temporalExtent*.

NOTE 2: Sensors (for example tide gauges deployed along a channel) are monitored by the data collecting Authority. After data acquisition, the data are quality controlled and stored by the Producing Authority.

See clause 7.1 for detailed descriptions of the types of water level data based on the time-dependence of the source.

12.4 Language

The language used for the Discovery Metadata and the Carrier Metadata is English. Producers may add translations of Feature Catalogues into additional languages using 'language packs' (cf. S-100 Part 18 and Part 11, clauses 11.2.4 – 11.2.5).

ANNEX A – Data Classification and Encoding Guide

A-1 Features

Water Level (*WaterLevel*)

<u>IHO Definition:</u> FEATURE: WATER LEVEL: The vertical position of a water surface			
S-104 Geo Feature: Water Level			
<u>Primitives:</u> pointSet, coverage			
S-104 Attribute	Allowable Encoding Value	Type	Multiplicity
Water Level Height	Must be in decimal metres, maximum resolution of 0.01 metres	RE	1
Water Level Trend	1 : Decreasing 2 : Increasing 3 : Steady	EN	1
Uncertainty	Must be in decimal metres, maximum resolution of 0.01 metres	RE	0..1

A-2 Feature Attributes

The number of attributes for *Water Level* is three: water level height, water level trend, and uncertainty. Encoding remarks are included with each attribute specification, below.

1. Water Level Height (*waterLevelHeight*)

<p>Water Level Height: The height of a water surface relative to a vertical datum</p> <p><u>Unit:</u> metre (m)</p> <p><u>Maximum Resolution:</u> 0.01 m</p> <p><u>Format:</u> xxx.xx</p> <p><u>Example:</u> 10.54</p> <p><u>Remarks:</u></p> <ul style="list-style-type: none"> Land mask or missing value is denoted by a unique number as specified in the metadata. The height is relative to some vertical datum, which is defined in the metadata. 0.01 metres equals 0.3937 inches (1 cm).
--

2. Water Level Trend (*waterLevelTrend*)

Water Level Trend: The tendency of water level to change in a particular direction.

1 : Decreasing (*decreasing*)

2 : Increasing (*increasing*)

3 : Steady (*steady*)

Unit: none (enumeration)

Resolution: N/A (enumeration)

Format: x

Example: 3 (Steady)

Remarks:

- To determine category, use metadata variable *waterLevelTrendThreshold* (See **Table 12-1**):
 - Decreasing: $\text{trend} \leq -\text{waterLevelTrendThreshold}$
 - Increasing: $\text{trend} \geq +\text{waterLevelTrendThreshold}$
- Steady: $-\text{waterLevelTrendThreshold} < \text{trend} < +\text{waterLevelTrendThreshold}$
Where a value is not known, the fill value must be populated, which is 0 (Unknown). The fill value may be used in non-tidal or similar regions.
- Native integer type H5T_STD_U8LE should be used for the base type of the numeric code (1, 2, or 3 here) when creating the enumeration.

3. Uncertainty (*uncertainty*)

Uncertainty: Estimate characterising the range of values within which the true value of a measurement is expected to lie as defined within a particular confidence level. It is expressed as a positive value.

Unit: metre (m)

Resolution: 0.01 metre

Format: xx.xx

Example: 0.02

Remarks:

- Represents a +/- value defining the possible range of associated depth, expressed as a positive number.
- Represents the uncertainty at a particular grid point and may be omitted if the uncertainty is the same at all grid points.
- If the water level height for a particular values record is the fill value for water level height., the uncertainty in that record must be the uncertainty fill value.

ANNEX B – S-104 Comprehensive Model Including Application Schema and Carrier Metadata (UML Diagrams)

Figure B-1 depicts the various components of the S-104 model. The Meta-features and Exchange Set Metadata components are empty because S-104 does not define any meta-features or extend S-100 Exchange Catalogue classes. Figure B-2 depicts the derivation of the S-104 packages from various S-100 components.

Kommenterad [rmm35]: Remove non-RG elements and non-RG diagrams

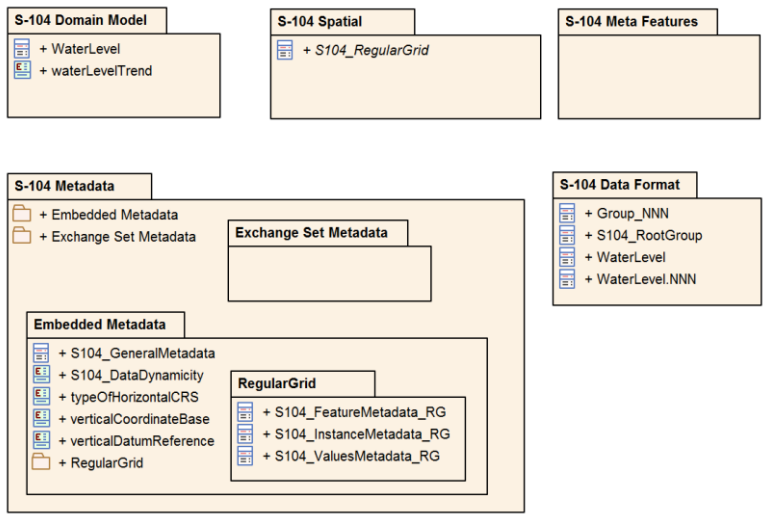

Figure B-1 – S-104 Model components

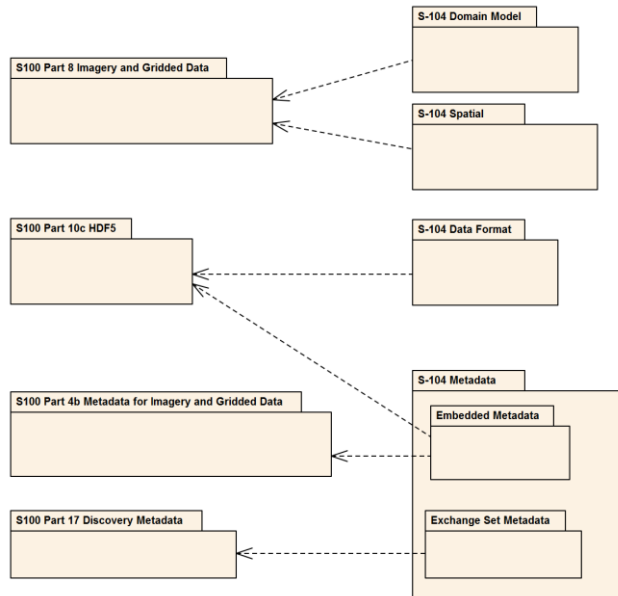

Figure B-2 – Derivations from S-100

Figure B-3 depicts the coverage types used in S-104 and their realizations from the conceptual coverages in S-100 Part 8 and ISO 19123. This is a more detailed version of **Figure 4-3**. Note that the realizations are not directly from the S-100 Part 8 and ISO 19123 classes, but via corresponding notional classes for the HDF5 implementations of the various data coding formats (not included in this diagram). For example, **S104_RegularGrid** is a notional extension of a notional S-100 class Part10c::S100_HDF_RegularGrid which encapsulates the encoding of *dataCodingFormat 2* in HDF5. The notional classes are omitted to reduce diagram clutter.

The implementation of most attributes in the S-100 Part 8 model by S-100 Part 10c closely follows the names and types of the attributes. Certain attributes in the S-100 Part 8 and ISO 19123 models are simplified in S-100 Part 10c HDF5 implementation, as follows:

- HDF5 Regular Grid and Ungeorectified Grid (data coding formats 2 and 3) implement S100_Grid and CV_ReferenceableGrid respectively:
 - The attribute *origin* is implemented in the form of two HDF5 attributes, *gridOriginLatitude* and *gridOriginLongitude*.
 - The attribute *offsetVectors* is implemented in the form of two HDF5 attributes, *gridSpacingLongitudinal* and *gridSpacingLatitudinal*.
- The *rangeType* attribute common to all coverage types is implemented implicitly in the S-100 Feature Catalogue's binding of attributes to a feature and in the name/datatype information in feature information datasets in the feature information group (S-100 Part 10c, Table 10c-8).

Page intentionally left blank

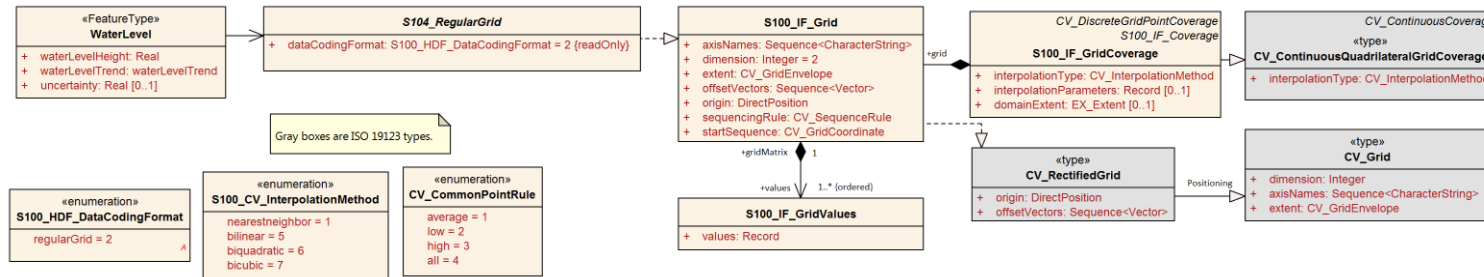

Figure B-3 Spatial Types – Coverages with Realizations from S-100 Part 8 and ISO 19123

Figure B-4 depicts the domain features. The **WaterLevel** feature and its attributes realise the values record in the S-100 Part 8 and ISO 19123 coverages models.

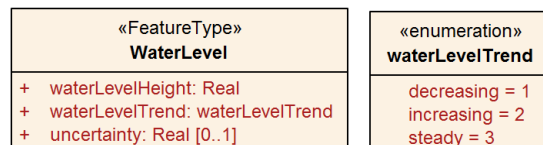

Figure B-4 – Domain Objects

Figure B-5 depicts the external catalogue metadata classes (the same information as **Figure 12-4**).

Figure B-6 depicts the same information as Figures 12-6 through 12-9, organised by coverage type instead of structural level. Different levels in the HDF5 structure (root, feature type, feature instance, and value) are indicated by backgrounds of different colours.

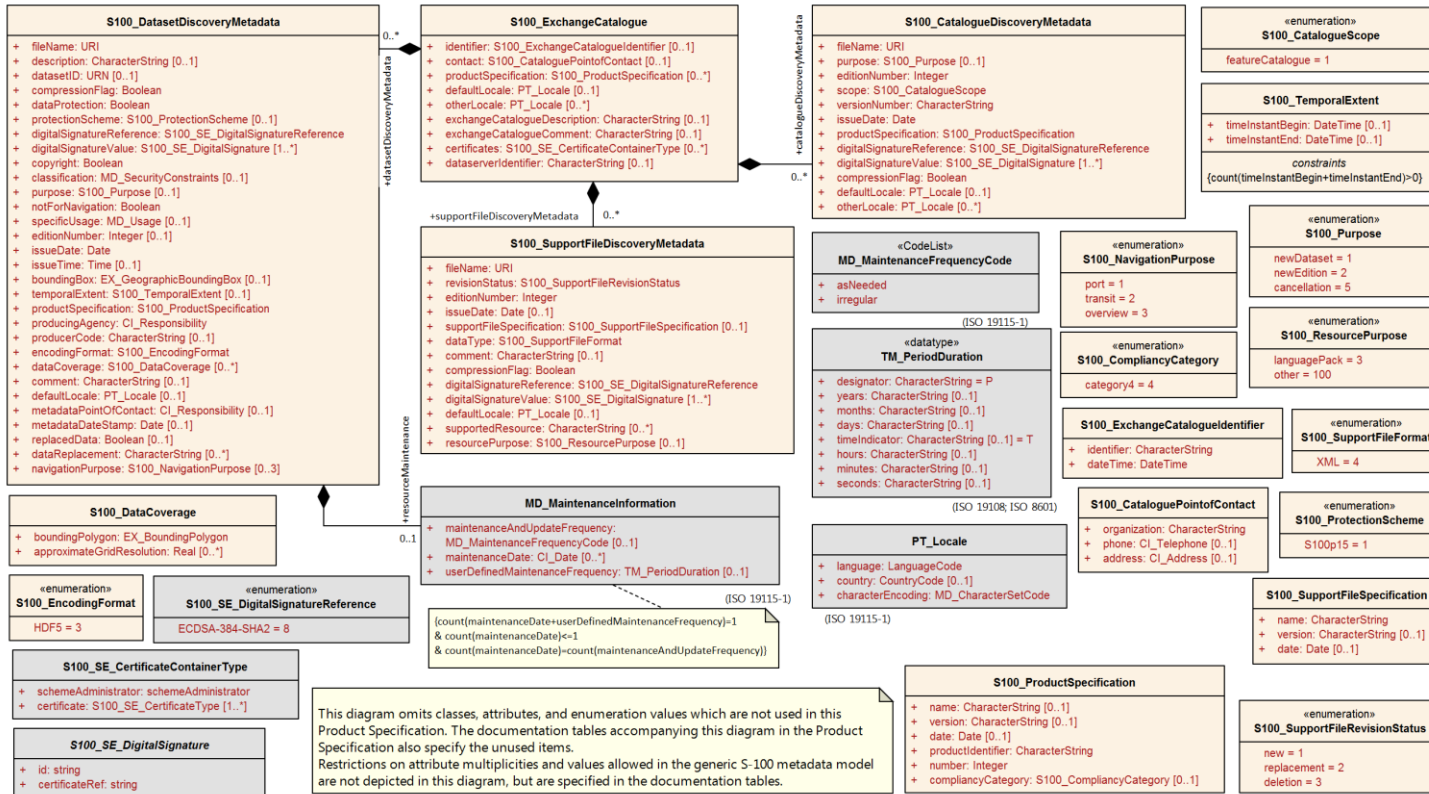

Figure B-5 – Exchange Set class details

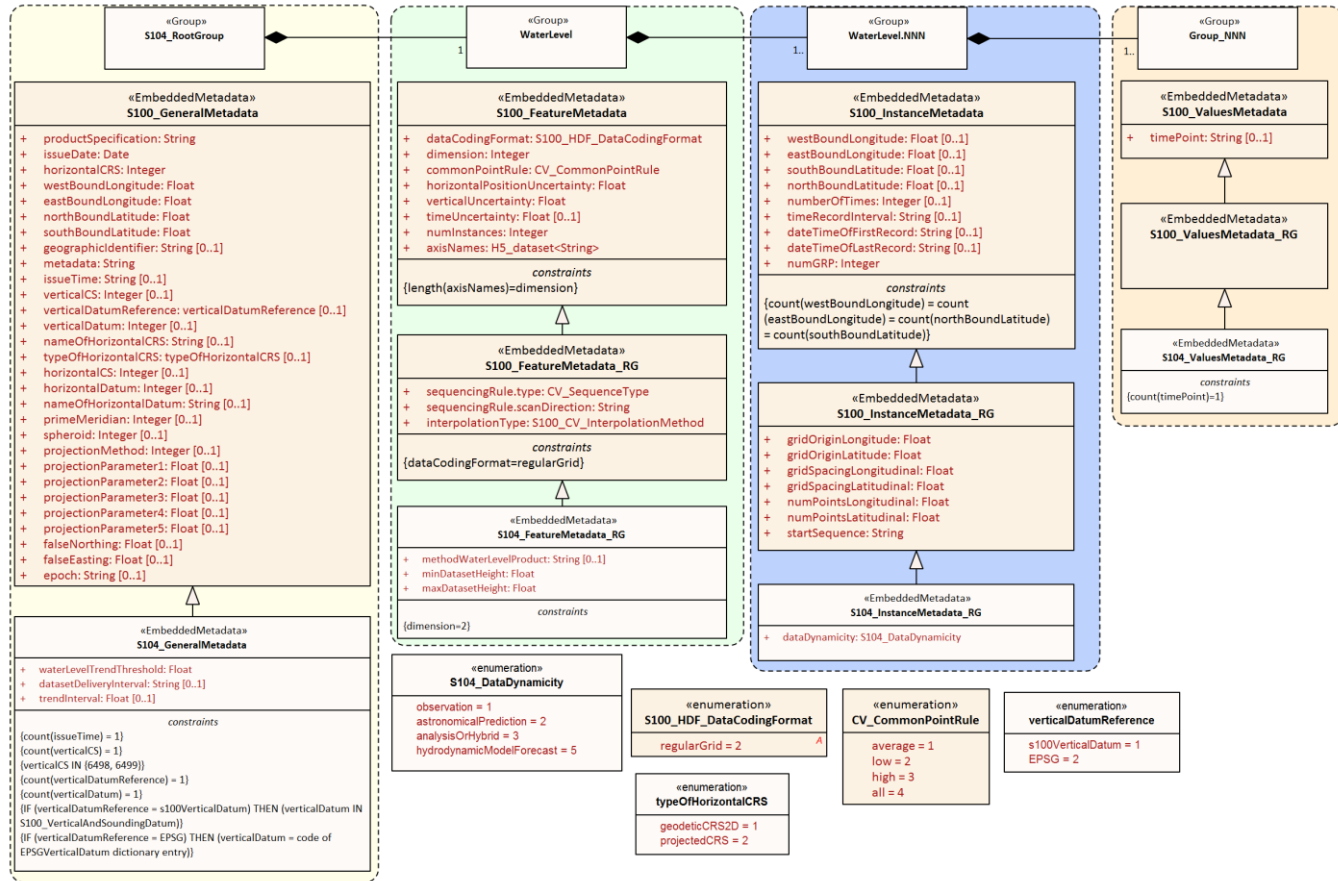

Figure B-6 – All carrier metadata for coverage type Regular Grid (data coding format 2)

ANNEX C – Feature Catalogue

C-1 Meta Feature Types

C-2 Geo Feature Types

C-2.1 Water Level

Definition: The vertical position of a water surface.

CamelCase: WaterLevel

Alias:

Super type:

Feature use type: geographic

Primitive: coverage

Remarks: No remarks.

Attribute Bindings:

S-104 Attribute	Allowable Encoding Value	Type	Multiplicity
Water Level Height		RE	1,1
Water Level Trend	1 : Decreasing 2 : Increasing 3 : Steady	EN	1,1
Uncertainty		RE	0,1

C-3 Cartographic Feature Types

C-4 Information Types

C-5 Simple Attributes

C-5.1 Water Level Height

Definition: The height of a water surface relative to a vertical datum.

CamelCase: waterLevelHeight

Alias:

Value type: real

Remarks: No remarks.

Unit of measure name: metre **definition:** SI metre **symbol:** m

Quantity specification: length

Constraints:

String Length	Text Pattern	Range		Precision
(not specified)	(none)	lowerBound	-99.99	2
		upperBound	99.99	
		closure	closedInterval	

C-5.3 Water Level Trend

Definition: The tendency of water level to change in a particular direction.

CamelCase: waterLevelTrend

Alias:

Value type: enumeration

Remarks: No remarks.

Listed Values:

Code	Label	Definition
1	Decreasing	Becoming smaller in magnitude.
2	Increasing	Becoming larger in magnitude.
3	Steady	Constant.

C-5.2 Uncertainty

Definition: The time of the water level height, expressed in Date-time format as specified by ISO 8601.

CamelCase: waterLevelTime

Alias:

Value type: real

Remarks: Represents a +/- value defining the possible range of associated depth, expressed as a positive number.

Unit of measure name: metre **definition:** SI metre **symbol:** m

Quantity specification: length

Constraints:

String Length	Text Pattern	Range		Precision
(not specified)	(none)	lowerBound	0.00	2
		upperBound	99.99	
		closure	closedInterval	

C-6 Complex Attributes**C-7 Roles****C-8 Information Associations****C-9 Feature Associations****C-10 Feature Catalogue XML**

The feature catalogue is provided as a separate XML file and can be downloaded from the IHO GI Registry.

Kommenterad [rmm36]: Remove waterLevelTrend if not needed for RG

Page intentionally left blank

ANNEX D – Sample HDF5 Encoding

The following are examples of HDF5 water level data files. The general structure of the data product is shown in Table 10-2, and the specific variables contained in the attributes are explained in Tables 12-1 – 12-10. The sample HDF5 files were produced by MATLAB® and were displayed in HDFView version 3.3.

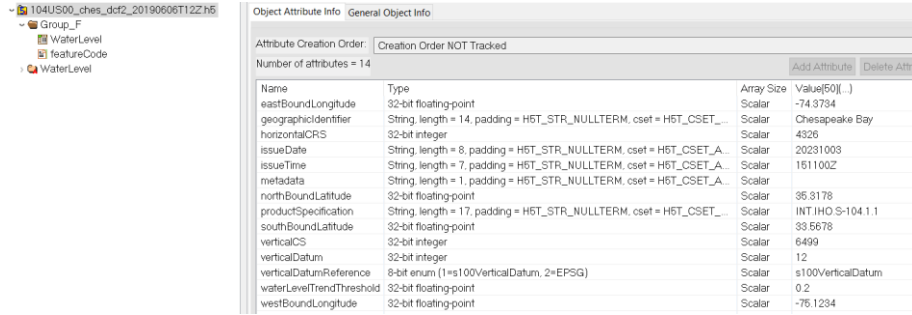

Figure D-1 – Typical root group structure and attributes

	code	name	uom.name	fillValue	datatype	lower	upper	closure
0	waterLevelHeight	Water Level Height	metres	-9999.00	H5T_FLOAT	-99.99	99.99	closedInterval
1	waterLevelTrend	Water Level Trend		0	H5T_ENUM			
2	waterLevelTime	Water Level Time	DateTime		H5T_STRING	1900010...	21500101T000000Z	closedInterval

Figure D-2 – Feature code array in Group_F

Kommenterad [rmm37]: Need sample without waterLevelTime and with uncertainty

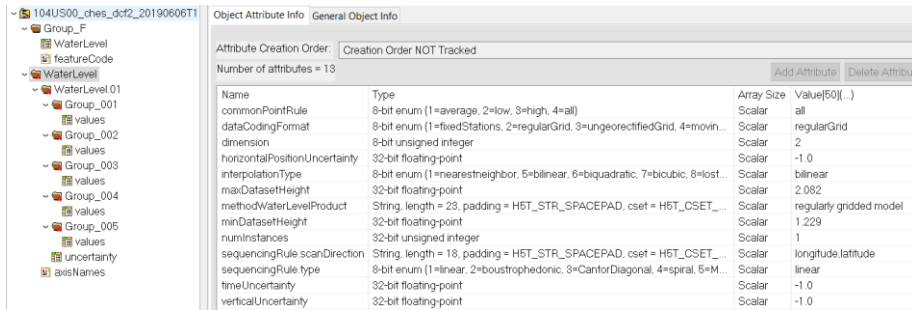

Figure D-3 – General structure of dataset (expanded on left) and attributes of feature type group (on right)

Name	Type	Array Size	Value[50](...)
dataDynamicity	8-bit enum (1=observation, 2=astronomicalPrediction, 3=analysisDrHybrid, 4=hy...	Scalar	hydrodynamicForecast
dateTimeOfFirstRecord	String, length = 16, padding = H5T_STR_SPACEPAD, cset = H5T_CSET_ASCII	Scalar	20190606T120000Z
dateTimeOfLastRecord	String, length = 16, padding = H5T_STR_SPACEPAD, cset = H5T_CSET_ASCII	Scalar	20190606T160000Z
eastBoundLongitude	32-bit floating-point	Scalar	-74.8734
gridOrignLatitude	64-bit floating-point	Scalar	33.567799
gridOrignLongitude	64-bit floating-point	Scalar	-75.123398
gridSpacingLatitude	64-bit floating-point	Scalar	0.25
gridSpacingLongitude	64-bit floating-point	Scalar	0.25
northBoundLatitude	32-bit floating-point	Scalar	35.3178
numGRP	32-bit unsigned integer	Scalar	5
numPointsLatitude	32-bit unsigned integer	Scalar	8
numPointsLongitude	32-bit unsigned integer	Scalar	4
numberOfTimes	32-bit unsigned integer	Scalar	5
southBoundLatitude	32-bit floating-point	Scalar	33.5678
startSequence	String, length = 3, padding = H5T_STR_SPACEPAD, cset = H5T_CSET_ASCII	Scalar	0.0
timeRecordInterval	16-bit unsigned integer	Scalar	3600
westBoundLongitude	32-bit floating-point	Scalar	-75.1234

Figure D-3 – Attributes of feature instance group

Name	Type	Array Size	Value[50](...)
timePoint	String, length = 16, padding = H5T_STR_SPACEPAD, cset = H5T_CSET_ASCII	Scalar	20190606T120000Z

Figure D-4 – Attributes of values group

	0		1		2	
	waterLevelHeight	waterLevelTrend	waterLevelHeight	waterLevelTrend	waterLevelHeight	waterLe
0	-9999.0	0	-9999.0	0	-9999.0	0
1	-9999.0	0	1.232	0	1.229	0
2	-9999.0	0	1.234	0	1.231	0
3	-9999.0	0	1.236	0	1.233	0
4	-9999.0	0	1.238	0	1.235	0
5	-9999.0	0	1.24	0	1.237	0
6	-9999.0	0	1.242	0	1.239	0
7	-9999.0	0	-9999.0	0	-9999.0	0

Figure D-6 – Selection from typical values dataset without node-level uncertainty data

Page intentionally left blank

ANNEX E – Validation (Informative)

E-1 Introduction

The following checks are intended for production systems designed to produce S-104 Water Level Information datasets. The checks can be administered at any time during the production phase. They can also be applied downstream in the distribution and end user systems to test the conformance of a dataset to the format rules specified in S-100 Part 10c and the S-104 Product Specification.

E-2 Check Classification

Checks are classified as critical, error, or warning checks as described in the Table below.

Table E-1 – Classification of checks

Category Code	Category Name	Category Description
C	Critical Error	An error which would make a dataset unusable in ECDIS through not loading or causing an ECDIS to crash or presenting data which is unsafe for navigation.
E	Error	An error which may degrade the quality of the dataset through appearance or usability but which will not pose a significant danger when used to support navigation.
W	Warning	An error which may be duplication or an inconsistency which will not noticeably degrade the usability of a dataset in ECDIS.

E-3 Check Application

Checks do not apply to dataset terminations or cancellations, except where the check description explicitly states it applies in case of a termination or cancellation.

The checks apply to each HDF5 file which constitutes a dataset (in the S-100 sense of “dataset” as an entire HDF5 file).

There being no update dataset format defined in S-104, checks are not designated as applying to “base” or “update” datasets.

E-4 Validation Steps

E-4.1 Dataset validation

Dataset validation checks the structure and content of individual HDF5 data files. The checks for each HDF5 dataset file are divided into five phases:

Table E-2 – Phases in validation processing for HDF5 datasets

Phase	Name	Description
1	Validate Dataset Root and Feature Information	Validation of root group of HDF5 file and feature type information.
2	Validate Feature Container Groups	Validation of metadata and structure for each feature type (“Feature Container”). In S-104 there is only one feature container, so this set of checks is executed only once. If future Editions introduce multiple feature container HDF5 groups, this set must be executed for each feature container HDF5 group.

Phase	Name	Description
3	Validate Feature Instance Groups	Validation of feature instances. This set of checks, along with Phase 4 and 5 checks, must be executed once for each feature instance group contained within a feature container.
4	Validate Position Information	Validation of positioning data. This set of checks is executed if and only if the data coding format requires the presence of explicit position arrays. For S-104 it consists of verifying that position arrays are not present, because the S-104 regular grid format does not use explicit position arrays.
5	Validate Values Datasets	Validation of values data. This set of checks is executed for each values group in a feature instance group.

Figure E-1 below depicts the sequence of processing. Certain check failures in Phases 1-3 prevent progress to later phases (because information needed to test conditions is not available). If one of these checks fails, processing of other checks in the current phase is allowed to proceed, but subsequent phases cannot be executed due to a lack of necessary information.

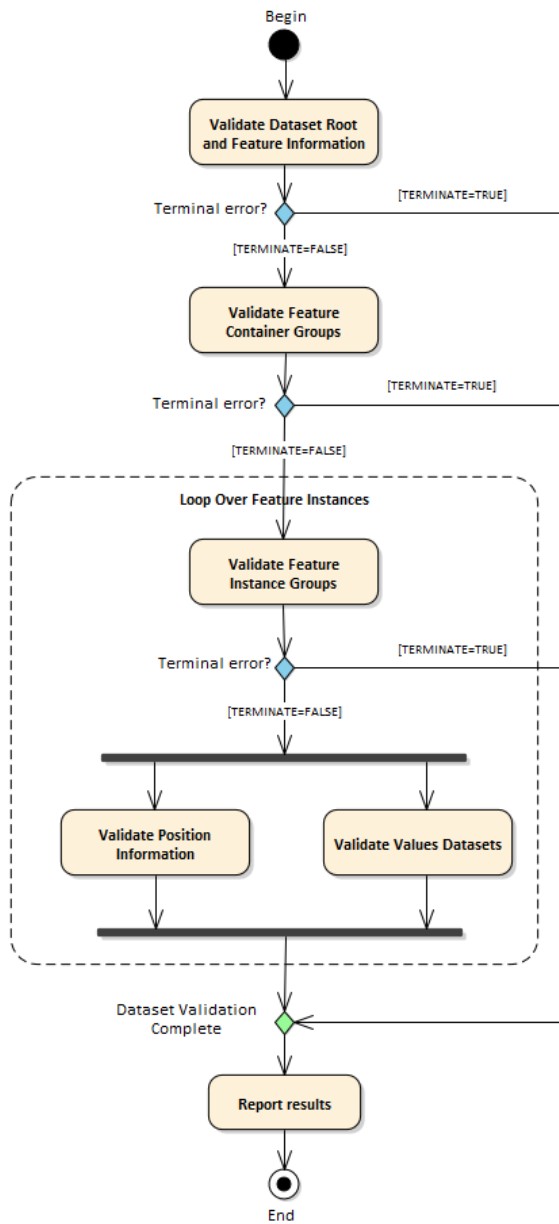

Figure E-1 – Phases of dataset validation processing

E-4.2 Exchange Set validation (informative)

Exchange Set validation involves the following phases.

- 1) Checking the presence and correctness of the Exchange Catalogue (CATALOG.XML).
- 2) Verification of signatures, including the Exchange Catalogue signature and signatures for individual datasets, catalogues, and support files.
- 3) Checking the structure and contents of the Exchange Set package, including whether there is a discovery block for each file in the Exchange Set.
- 4) Checking that the metadata encoded in a discovery block and the headers and embedded metadata in the corresponding dataset or Catalogue are compatible.

Generalised checks for Exchange Set validation are being developed by the S-100WG and will be introduced into S-104 when ready.

E-4.3 System validation (informative)

System validation consists of verifying the suitability of the Exchange Set and dataset for its intended use and its compatibility with other data products with which it will be used. For example, an S-104 dataset intended for use on an ECDIS should:

- Conform to the applicable user experience requirements for coverage data specified in S-98 Annex C (User Experience);
- Use the same datum as the underlying ENC(s), in order to be usable for water level adjustment calculations.

The requirements for system validation are under development at this time and will be described later, possibly in a separate Specification.

E-5 Check Description Format

E-5.1 Specification of validation checks

Individual checks are defined in the format described in Table E-3.

Table E-3 – Check specification format

Column	Description
Data Quality Measure or Theme	Quality measure or theme from S-97 Part C. If two measures are included in this column, the Comments column explains how the error should be classified.
Check ID	Identifier for check.
Short Name	Short name for the check.
Prerequisite check(s)	Checks which must succeed (check condition evaluates to FALSE) before this check can be executed.
Context test (IF ...) or initialization (SET ...)	Combination of test conditions and initialization statements. Test conditions check for the existence of an HDF5 attribute, group, or other element (for example, an HDF5 array), or test the value of a metadata attribute. Initialization statements set the value of parameters used in the specific test in that row. The scope of the test condition or initialization is limited to the check described in that row.
Check condition description	Specification of check condition, written in structured English. The conditions are written so that if the condition evaluates to TRUE it indicates an error or other issue exists in the dataset.
Check message	Message to emit if dataset fails the check condition (condition evaluates to TRUE).
Check solution	Solution to be applied to correct the failure.

Column	Description
Classification	Whether check failure is a Critical, Error, or Warning issue. See Table E-1.
Post-condition	Action to be executed if the check condition evaluates to TRUE (that is, if the check fails). This action will generally either set a global flag to control check processing (for example, "SET TERMINATE=TRUE") or set a variable in the processing context which is used in later checks (for example, set a context variable to store the value of the metadata attribute <i>dataCodingFormat</i>).
S-100 reference	Reference to place in S-100 where more information about the check can be found, for example lists of allowed values for enumerations. All S-100 references for checks conforming to this Edition of S-104 are to S-100 Edition 5.0.0.
S-104 reference	Reference to place in S-104 where more information about the check can be found, for example allowed values for attributes of enumeration types.
Comments	Explanatory remarks or additional notes.

E-5.2 Phase initialization

Certain parameters need to be initialized before processing of the phase begins. The required initialization statements are indicated in a sub-head row at the beginning of each phase.

E-5.3 List of checks

The individual checks are given in a spreadsheet file accompanying this Product Specification. The checks are a part of this Product Specification. Two sheets are included, for dataset checks and Exchange Set checks respectively.

Words in angle brackets <> indicate the content is a parameter which must be substituted by the appropriate value. For example, <FX> (Phase 1 in the dataset checks) should be replaced by the appropriate feature code ("WaterLevel" for S-104).

Bold type indicates a literal name (for example **Group_F.featureCode** means the HDF5 array named "featureCode" in the HDF5 group named "Group_F").

E-6 Test Cases and Methods

E-6.1 Coverage consistency

E-6.1.1 Test case for coverage geometry

Test purpose:	Verify that the coverage geometry corresponds to the conformance class.
Conformance clas:	Gridded coverage, point coverage.
Test method:	Check that the coverage geometry type complies with one of the coverage types defined in the Application Schema in clause 4.2.
Test type:	Basic.

E-6.1.2 Test case for extra data

Test purpose:	Verify that a Gridded coverage data set is complete by testing that the grid coverage value matrix contains height and trend, or fill values, for every vertex point defined in the grid, and when all of the mandatory associated metadata is provided. Verify that a Point Coverage is complete by testing that the points containing height and trend values are matched with a longitude-latitude pair, and when all of the mandatory associated metadata is provided.
---------------	---

Test method:	Check that for each feature, all of the mandatory metadata is provided, and that all of the vertex points have corresponding values.
Test type:	Basic.

E-6.1.3 Test case for empty data

Test purpose:	Verify that data is not missing.
Test method:	Check that all mandatory metadata is provided, and test that all data values for the grid or point coverage established in the metadata are provided.
Test type:	Basic.

E-6.2 Logical consistency

Check that grid extent defined in the metadata is consistent with grid spacing and number of points. Check that the number of null values in the speed grid equals the number in the direction grid. Check that the point coverage envelope is consistent with the minimum and maximum point locations.

E-6.2.1 Conceptual consistency

The implementation of the Water Level Product is required to align with one of the two conformance classes defined in S-100 Part 8, Appendix 8-A - Abstract Test Suite.

E-6.2.2 Domain consistency

The attributive values are validated to ensure they are within defined range.

Test purpose:	Verify that attribute values are within specified ranges.
Test method:	Check that the water level height attribute values are within the range - 99.99 to 99.99 metres or are the fill value and that the trend values are consistent with the enumeration specified or are zero. This would be validated by means of test software.
Test type:	Basic.

E-6.2.3 Positional accuracy

For a gridded coverage the positional accuracy for the grid reference point and the length of the offset vectors defining the size of each grid cell, when specified, are defined in the metadata.

Test purpose:	Verify that the grid reference point and offset vector in a grid coverage, and the points in a point coverage, are defined and in accordance with the accuracy established for the data set by the Producer.
Test method:	Verify that the positional accuracy of the defining points of the coverage is within the accuracy established for the data set by the Producer, in particular the Hydrographic Office, by the use of test software.
Test type:	Basic.

E-6.2.4 Temporal accuracy

For a gridded coverage the temporal reference time for the data at all grid points is the same. Temporal accuracy is not defined.

ANNEX F – Use Cases

F-1 German Water Level Data and Forecast

F-1.1 Summary

Name:	German S-104 Water Level Data and Forecast. (Courtesy: BSH - Bundesamt für Seeschifffahrt und Hydrographie).
Description:	<p>The usage of S-104 format for data delivery and the operational regular data transfer in near real time allows several applications. The optimised water level forecast builds the basis for safe navigation, especially in areas with strong tides, as the inner German Bight. The S-104 data may be used for route planning, allowing to adapt to changing water depth. Optimised water level forecasting leads to better route monitoring as well as route planning and a more efficient loading of ships.</p> <p>Furthermore, the potential data transfer on ships helps for direct navigation of a vessel. It will allow a more efficient usage of narrow shipping channel or areas with high traffic density.</p> <p>The main users are shipping companies and administration, pilots, and organisations for harbour and waterway management. Further applications are possible in fields of civil protection, protection of marine environment, support of offshore and coastal activities, as well as coastal engineering.</p>
Potential Actors:	Navigators, Marine Pilots, Shipping Companies, Vessel Control Centres, Ship and Harbour Managements, Port Authorities, BSH (Bundesamt für Seeschifffahrt und Hydrographie), WSV (Wasserstraßen- und Schifffahrtsverwaltung des Bundes).
Potential Applications:	<ol style="list-style-type: none"> 1. Route monitoring. 2. Route planning and forecast of safety corridor. 3. Other applications as civil protection, protection of marine environment, support of offshore and coastal activities, as well as coastal engineering.
Data Requirements:	<ul style="list-style-type: none"> • High quality water level forecast (with adequate spatial and temporal resolution). • Astronomical prediction. • Near real time observational data.
Technical Aspects and Post-Processing:	<ul style="list-style-type: none"> • Different kinds of water level data are stored in one file. Portrayal of real time observation, optimised water level forecast and astronomic prediction with the help of a WMS. • Transformation of all kinds of data. • Route planning with respect to forecasted water level.

F-1.2 Additional details

F-1.2.1 Types of data used to create S-104 test datasets

1. Operational Numerical Forecast Model Output
 - a. Hydrodynamic model forecast for Elbe Estuary / German Bight
 - b. 90m x 90m grid spacing / 900m x 900m grid spacing
 - c. Forecast interval: 48h, 15 Minutes time step
 - d. 1155 x 728 grid points / 1030 x 1761 grid points
 - e. Update: 2 times daily
2. Observation
 - a. Discrete observations from gauge stations

- b. Time spacing: 1 minute
- c. Update: near real time
- 3. Astronomical prediction
 - a. Forecast for discrete locations
 - b. Long range prediction
 - c. Update: yearly
- 4. Model output statistics [MOS]
 - a. Statistical method for optimizing numerical model forecast
 - b. Available for some locations
 - c. Forecast up to 7 days
 - d. Time spacing: 15 Minutes
 - e. Update: every 15 Minutes

F-1.2.2 Data processing

Numerical model output and model output statistics (MOS) at several stations have been combined for an optimised areal water level forecast. The method uses the surface shape of a hydrodynamic model forecast and corrects it with high accurate MOS forecasts at specific locations. This leads to an overall optimised and frequently updated water level surface forecast.

F-1.2.3 S-104 data transformation

The data described above, especially the post processed data, builds the basis for the creation of S-104 test data sets. The transformation of different formats are achieved by a tuple of tools:

1. S-104 regular grid converter
 - a. Input: Hydrodynamic model forecast (MOS-corrected)
 - b. Output: S-104 conformant HDF5 file
2. S-104 station data converter
 - a. Input: Observation, Astronomic Prediction, MOS-Data, Numerical Model data (MOS-corrected) for discrete locations
 - b. Output: single S-104 HDF5 file

F-1.2.4 Results

Figure F-1 shows one application of S-104 datasets; a WMS to display the S-104 data for the use case pick report. The request pops up a figure displaying the data described above. The green line represents the observation, blue the astronomical prediction and black represents the hydrodynamic model forecast optimised with MOS. The purple line shows the difference between prediction and hydrodynamic model forecast.

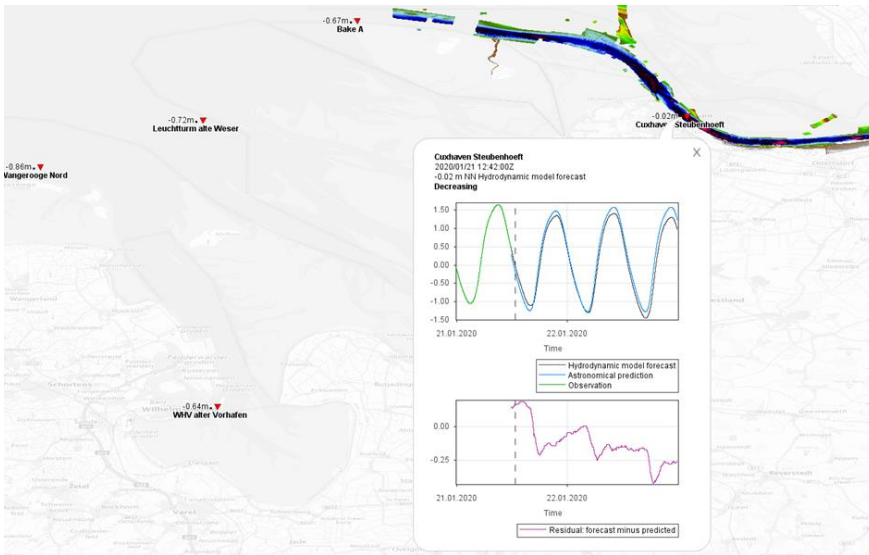

Figure F-1 – Pick report for S-104 test data

As a practical example, S-104 datasets were produced as a suitable format to deliver different kinds of water level data in one file. A regular data transfer via FTP has been established and the S-104 data has been integrated in a WMS for a highly frequented region. The “pick report” portrayal has been implemented. It has been confirmed by consensus of a user workshop that the display of water level data as a pick report like specified in S-104 is good practice.

F-2 Depth Adjustment in ECDIS

F-2.1 Summary

Name:	Depth adjustment in ECDIS.
Description:	S-104 data may be used for route planning, in combination with S-101 ENC and S-102 Bathymetric Surface data to provide navigation officers with dynamic water depth information for the purpose of route planning. This will allow efficient use of waterways with tidal or other dynamic variations of water levels, saving vessels transit time and fuel costs. The main users are commercial vessels and pilots.
Potential Actors:	Navigators, Marine Pilots, Hydrographic Offices.
Potential Applications:	<ul style="list-style-type: none"> Route planning and assessments of safe depths. Safety contours according to dynamic depths instead of the static contours currently provided by ENC data alone.
Data Requirements:	<ul style="list-style-type: none"> High quality water level forecast (with adequate spatial and temporal resolution). Astronomical prediction. Near real time observational data. S-102 bathymetry data (with adequate spatial resolution). Availability of underlying ENC data. Vertical datums in S-102 and S-104 data should match.

Technical Aspects and Post-Processing:	<ul style="list-style-type: none"> • S-104 data must be provided as a continuous coverage (data coding format 2 (regular grid), 3 (ungeorectified grid) or 7 (TIN)). • ECDIS must implement S-98 Annex C interoperability in order to integrate S-101, S-102, and S-104 data. • ECDIS must have functionality to implement route planning with respect to forecasted water levels.
---	---

F-2.2 Additional details

F-2.2.1 Types of data

S-104 data, available as forecasted data in grid format covering the projected time of the transit and the planned route.

S-102 data, available in grid format covering the planned route.

Relevant vessel parameters (draught, squat) are available to the ECDIS.

F-2.2.2 Processing

The ECDIS is used in route planning mode and the navigator plots the planned route or imports it from a S-421 dataset.

The navigator sets the projected start time of the transit and the route parameters such as speed over ground, cross-track deviation, etc.

The navigator selects a time interval based on the speed of the vessel and the time record interval between S-104 records that is encoded in the S-104 forecast data (see **Table 12-3**).

Adjustment zones are created by the ECDIS based on the route schedule, speed, and a buffer (calculated either as a multiple of cross-track deviation or a user-specified value). The extent of each adjustment zone depends on the speed and cross-track buffer.

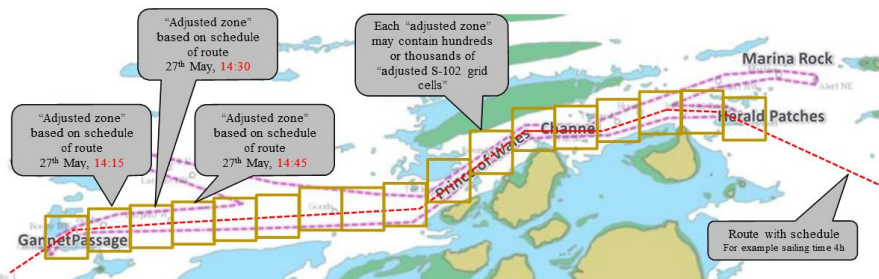

Figure F-2 – Adjustment zones based on planned route (courtesy: Furuno Electric Company, Ltd)

The ECDIS computes an “integrated and dynamic safety contour” in the region covered by the combined adjustment zones, computed from bathymetry data adjusted by the dynamic water levels extracted from the S-104 record(s) corresponding to the time the vessel is transiting each adjustment zone.

Page intentionally left blank